



iFLOW MANUAL A2

INTELLIGENT SMART IoT TECHNOLOGIES
iFLOW HYDRONIC AIR HANDLER
NEW GENERATION OF HEATING & COOLING



i Table of Contents

Introduction

Safety	2
Summary of air handler	2
Technician checklist	2

Product Description

Components	3
Standard features and benefits	4
Equipment selection and sizing	5
Suitable Applications (Choosing the correct heat source)	5

Installation

Location requirements and clearances	8
Dimensions	8
Installation examples	9
Boiler Piping	9
Domestic Piping	9
Electrical requirements and making connections	10
Temperature sensors	10
A/C Evaporator Coil Freeze Protection and the Importance of Wiring the A/C Compressor to the Proper and Dedicated A/C Connector on the iFLOW PCB.....	11

Start-Up

Procedure	14
Flushing the heat exchanger	14
Sequence of operation.....	14

Service and Maintenance

Maintenance	18
Checking temperature sensors	18
Wiring Diagram	19
A2 Field Wiring	20
iFLOW Set up and Wiring of an iFLOW with a Heat Pump	21

Troubleshooting

Fault Codes and Explanations	24
Problems and Solutions	25
Component Assembly Diagram and Parts Lists.....	26
Commonwealth Of Massachusetts Board Policy	35

Warranty

Warranty Information.....	36
Contact Information	36

i Introduction

1. Introduction Safety

Ensure the instructions and requirements provided in this manual are read and understood before installation. Failure to comply with these instructions can cause product and property damage, serious injury or death.

Pay attention to the following safety symbols and words:



DANGER

Indicates an imminently hazardous situation, which if not avoided, will result in death or serious injury.



WARNING

This product can expose you to chemicals including lead, lead compounds, and carbon bisulfide which are known to the State of California to cause cancer and birth defects or other reproductive harm. For more information, go to www.P65Warnings.ca.gov.



CAUTION

Indicated a potentially hazardous situation, which if not avoided, may result in minor or moderate injury. It is also used to alert against unsafe practices and hazards involving property damage.

2. Summary of air handler

The iFLOW hydronic air handlers are designed to deliver the highest performance rating of any air handler regardless of the hot water source. This unique hydronic furnace is built for use in residential and commercial applications.

3. Installer's checklist

- Be sure to bleed all air from all system components and piping prior to start-up.
- It is recommended to install purge valves between the air handler and water heater's isolation valves.
- If connected to domestic piping creating an open system, make sure all piping, components, and solder are lead-free and approved for potable-use.

CAUTION

Return air opening shall not be installed on the back side of unit.

IMPORTANT

The maximum ambient temperature must not exceed 122°F (50°C)

- Ensure fan assembly is clear of any obstruction
- Check that air filter is installed upstream of air conditioning coil.
- If the appliance is installed with air conditioning, the A/C refrigerant charge and system operation must be verified by a certified/ licensed mechanic prior to commissioning.

WARNING

This Air Handler Unit (AHU) is not intended for installation in a unconditioned space where the potential may exist for the water and/or drain lines to freeze.

CAUTION

The air handler must be installed such that electrical components are away from water (spraying, splashing, etc.) during operation and service.

IMPORTANT

A field fabricated auxiliary drain pan with a drain pipe connection is recommended in all configurations.

i Product Description

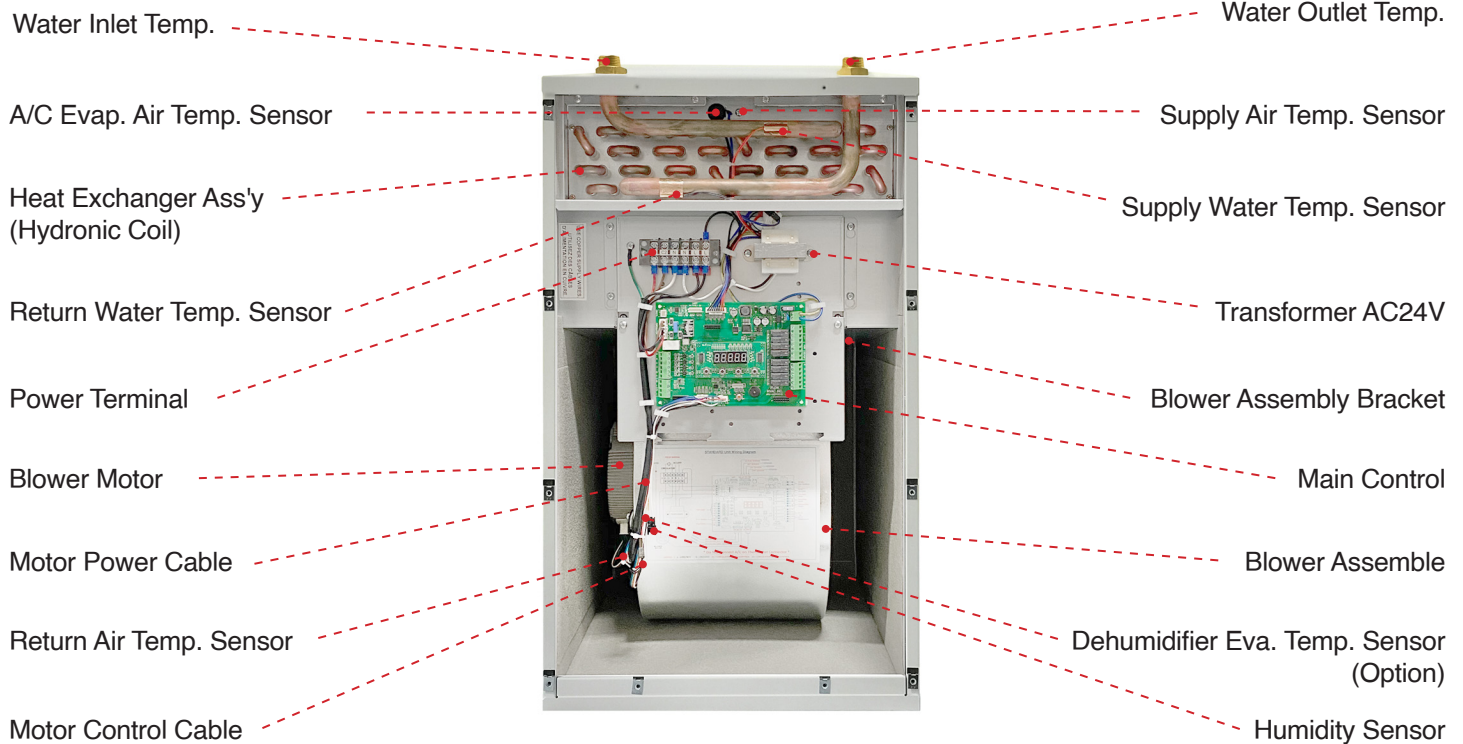

Cabinet:

All cabinets are made of high quality, and durable heavy gauge galvanized steel. The inside of the cabinet is fully insulated with ½” polyethylene sheets. This prevents moisture and mold growth, as well as unwanted heat loss due to an R-Value. The smaller cabinet size and shape is designed to maximize installation flexibility.

Heating Coils:

All iFLOW heating coils are constructed of potable, water-grade copper for use in plumbing systems. Lead-Free solder has been used for assembly on all components. All coils and internal piping conform to ASTM B-68, ASTM B-88 and/or B-743 standards. Carefully engineered, high-density aluminium fins allow for maximum heat transfer across smaller coils. This provides warmer, more comfortable heating with lower air flow for minimal operating noise.

Fan Motor:

All iFLOW air handlers are equipped with variable speed ECM motors. This allows for separate heating, cooling, and continuous run speeds. They reduce electrical-use and are dynamically balanced for extra quiet operation. Blowers are mounted with four screws on rails for easy removal and service. Multi-directional motors allow for mounting in any direction.

Circulating Pump:

All air handlers require a field supplied single speed or 3-speed pump, to be controlled by the iFLOW circulator control. This the speed of the pump increases or decreases depending on the information provided by the temperature sensors. The pump also provides maximum performance when used in conjunction with an instantaneous water heater or a storage-type water heater.

Check Valve:

A spring-loaded check valve must be installed either with the field-supplied pump or externally to prevent the by passing of water to the appliance.

Multi-Function Control Board:

This intelligent control board comes factory installed. No dip switches are required or included with the iFLOW control board. Easy programming allows for user-friendly startup and service/maintenance. Some of the parameters the user is able to configure are: heating output, CFM for heating, cooling and continuous low-speed fan, outdoor design temperature and circulating pump speed.

2) Standard Features and Benefits:

- Highest performance at 98% efficiency (CAN/CAS P.9-11 Performance Ratings: TPF 0.98)
- Ultra-efficient heat-exchanger design with high-density aluminum fins
- Offers installation flexibility allowing for up-flow, down-flow or horizontal applications
- Cost effective and extremely quiet variable speed ECM fan motor / constant CFM
- Slide-out blower rail assembly for easy maintenance & removal with 4 screws
- 6 fully modulating models: 3 'standard duct' models (S, M, L) & 3 high-static pressure models (S, M, L)
- Easy installation: Lightweight, "one-man job" with Optional EZEE Plumbing Kit
- Approved for potable water ('open') systems with built-in anti-stagnation and DHW priority included in the control board
- Air and water supply and return temperature sensors included
- Humidity sensor included for cooling fan speed modulation
- Freeze Protection/ Evaporator Temperature Sensor
- Outdoor temperature sensor included
- Intelligent iFLOW control board
- All models are compatible with mercury or digital thermostats
- Supports the use of two stage and inverter-driven variable speed cooling equipment
- Accessories are controlled by AC24V power
- LED light indicates alarm, test mode and normal operation
- Auxiliary contacts (dry contact) for boiler or water heater activation
- Bottom or left or right side return air supply
- 0" clearance to combustibles
- Cabinet lined with 1/2" Polyethylene High-Density Insulation
- Cabinet manufactured with heavy gauge galvanized steel and powder-coated to prevent corrosion

INTELLIGENT PUMP CONTROL:

- Pump modulation control
- Low flow pump exercise function (Water Circulation / Seize Protection)
- Low ambient freeze protection

INTELLIGENT CONTROL:

- Boiler demand control
- Installer & user-friendly interface
- Informative display: error code, temperature, humidity, fan & pump speed
- Easily configure all parameters smartphone App.
- 22 segment LED indicator / all input & output signals: built-in programmable and diagnostic control display
- Outdoor reset function / outdoor temperature sensor
- Full modulation a single or two stage settings for heating & cooling
- Humidity control / humidity sensor
- ΔT auto-adjustment air and water (air and water flow control)
- Fan "ON" delay & Fan "OFF" heat purge control

- DHW priority & dual mode (heating and DHW)
- High & low limit safety control: air temperature sensor
- Home freeze protection: low ambient temperature sensor
- Evaporator freeze protection: compressor protection
- Virtual thermostat mode with the smartphone app
- Smart zoning control (saving gas & hydro)
- Maximize heat pump performance / (AVOID) Peak Time AVOID Electricity Function
- Hybrid heating system switching control and backup with heat pump
- Communication with NAVIEN Tankless Water Heater

OPTIONS:

- Multi-system central control for building HVAC systems
- Wi-Fi connection with a smartphone (Free app available on iOS and Android)
- Remotely adjust and monitor operation through web integrated plug-in control, or directly via a smartphone connection
- All-in-one package (EZEE plumbing kit and stand) for easy Installation: iFLOW AHU with any TLWH/TWH

Freeze Protection:

iFLOW Air handlers include a freeze protection sensor that will temporarily disable the outdoor condenser for 5 minutes if the evaporator coil outlet temperature drops below 40°F/4°C. This will allow the system to warm up and return back to normal operating conditions.

To protect the hydronic heating coil from freezing, the pump will operate for a minimum of 30 seconds. Dirty air filters, oversizing of A/C equipment, improper A/C installation or poor duct design will also play a role in the evaporator coil freezing.

Water Circulation / Pump Exercise:

In section 4.2.5.1 Prevention of Stagnation of the 'CAN/CSA-B214-12 Installation Code for Hydronic Heating Systems', it states: "a means shall be provided to prevent the stagnation of potable water in a hydronic system by recycling or flushing the contents not less than once every 24 hours."

The iFLOW controller is defaultset to turn on the circulating pump to cycle the total volume of potable water in the system, once every 24 hours. This will prevent stagnation and protect the pump from seizing. There is a test button to verify that this operation is working. The setting can be adjusted to circulate more frequently if desired.

Alarms:

In the event of a service problem (i.e. temperature sensor failure, low ambient temperature, cooling lockout, etc.), the iFLOW air handler will notify the user/owner with an audible alarm and red light. The alarm on the control board can be silenced by turning the power off for 5 seconds and then back on.

Set Back Recovery:

If a programmable thermostat with setback is used or a sudden increase in temperature is required, the iFLOW intelligent control board will modulate the air handler to its maximum output to speed temperature delivery. The next cycle will return to normal operation. See "Heat Boost Delay" Parameter.

Test Mode:

Entering 'test mode' on the controller will allow the technician to test the iFLOW air handler heating and cooling mode parameters. Once completed, push the test button again to return to normal operation.

Heating:

The iFLOW air handler will automatically change the fan and pump speeds to control the temperature output of the unit and cycle-time length. This will allow the heat output of the air handler to match the current heat loss of the home. Maximum 'matching' performance is achieved when used in conjunction with the outdoor sensor. This leads to a longer runtime, providing superior warmth and comfort.

Cooling/Dehumidifying:

The iFLOW air handler uses a modulating blower fan to regulate humidity levels. The blower fan speed decreases in high humidity to remove moisture quicker. The blower fan speed increases under normal conditions to provide optimal cooling. The balance of the two is always met. Optimal humidity levels result in increased comfort for the homeowner, and at the same time reduces cooling loads and operating costs.

3. Equipment selection and sizing

iFLOW air handlers are available in 3 models. Please use the following charts to determine which best suits the application:

1. Obtain/calculate/determine a proper heat load for the home
2. Determine the inlet water temperature from water heater(or boiler)
3. Determine the duct layout/ available duct size
4. Be sure the system air flow rate matches the air flow rate of the selected air handler

System Design Resource Note:

From the CAN/CSA-B214-12 Installation Code for Hydronic Heating Systems, section 4.2.2.1 Heat-source output, it states: "the heat-source output shall be not less than the heat load indicated in the system design."

4.2.2.2 Dual-purpose water heater

Model No. Description

Model No.	Description	WiFi @ IoT	Zoning	Temperature Control
iFLH-140000	iSmart Control	No	No	Room Thermostat
iFLH-160000				
iFLH-180000				

Model No. Description

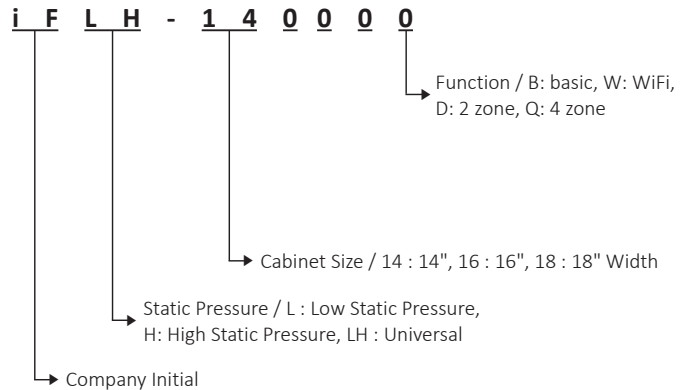

Model No. Format

Model No. Initial	Size	Function Initial
i F L H	14, 16, 18	B, W, D, Q, 0

4. Suitable applications: Choosing the right heat source

The iFLOW air handler can be installed with various types of heat sources and heating systems. The following are its primary applications:

1. Air handler with tankless water heater
2. Air handler with conventional tank-type water heater
3. Air handler with heating boiler
4. Air handler with combi boiler
5. Air handler with heat pump + tankless water heater
6. Air handler with heat pump + tank-type water heater
7. Air handler with heat pump + boiler
8. Air handler with heat pump + combi boiler

Refer to the installation manual for diagrams of each type of installation.

i Specification

Description		iFLH-140000	iFLH-160000	iFLH-180000
Heating Capacity @ Entering Water Temperature	120°F	27,834 BTUH	34,211 BTUH	42,376 BTUH
	130°F	33,478 BTUH	41,357 BTUH	50,966 BTUH
	140°F	37,729 BTUH	48,379 BTUH	59,632 BTUH
	150°F	44,998 BTUH	55,485 BTUH	68,334 BTUH
	160°F	50,869 BTUH	62,632 BTUH	77,065 BTUH
	170°F	56,941 BTUH	69,769 BTUH	85,648 BTUH
	180°F	62,786 BTUH	76,982 BTUH	94,633 BTUH
Flow Rating	LPM / GPM	11.4 / 3	11 / 2.9	10.6 / 2.8
Return Air Temp.	°C / °F	22 / 72	22 / 72	22 / 72
E. S. P.	inWC	0.6 / 1.2	0.6 / 1.6	0.6 / 1.6
Airflow	SCFM	941 / 824	1222 / 1009	1423 / 1093
Cooling Capacity	Ton	1 - 2	1.5 - 3	2 - 4
Cabinet Size (W x D x H)	in	14 x 18 3/4 x 27 1/8	16 x 20 3/4 x 27 1/8	18 x 25 3/4 x 29 1/8
	mm	356 x 476 x 689	406 x 527 x 689	457 x 654 x 740
	Material	Cold Roll Steel Sheet Metal / Powder Coated		
Weight	kg	28.6	32	42
	lb	63	71	92.5
Supply Air Opening (W x D)	in	13 x 14	14 x 16	16 x 20
	mm	330 x 356	356 x 406	406 x 508
Return Air Opening (H x D)	in	12 x 16	13 x 18	14 x 23
	mm	406 x 304	457 x 330	584 x 355
Electrical	ACV/Hz/Ph	AC 120V 60Hz 1Ph	AC 120V 60Hz 1Ph	AC 120V 60Hz 1Ph
Motor	HP	1 / 2	1 / 2	3 / 4
	Type	ECM Eon	ECM Eon	ECM Eon
	W	431 / 393	519 / 516	592
Piping Connection	Supply	3/4" Male NPT Thread / 1/2" Soldering Connection		
	Return	3/4" Male NPT Thread / 1/2" Soldering Connection		
Hydronic Heating Coil		Aluminum Ultra Efficiency Fins, Copper Tubing		

Water Heating Capacity (BTUH) / Water Pressure Drop (Feet)

iFLH-140000

H.Ex. Rows	Entering Water Temp.	3 GPM						4 GPM					
		CFM					W.P.D	CFM					W.P.D
		400	600	700	800	950		400	600	700	800	950	
4	120°F	17,365	21,756	23,654	25,347	27,834	2.9	18,425	23,097	25,653	27,246	29,906	4.3
	130°F	20,756	26,235	28,105	30,632	33,478	2.9	21,365	27,743	30,014	32,954	36,183	4.3
	140°F	24,142	30,754	33,521	36,065	37,729	2.8	24,845	32,469	35,478	38,549	42,376	4.2
	150°F	27,587	35,329	38,013	41,365	44,998	2.8	28,326	37,254	40,024	44,287	48,598	4.2
	160°F	30,965	39,865	43,247	46,759	50,869	2.8	31,824	41,987	45,726	49,976	54,843	4.1
	170°F	34,329	44,432	48,628	52,125	56,941	2.7	35,327	46,743	51,214	55,643	61,176	4.1
	180°F	37,734	49,032	54,573	57,683	62,786	2.7	39,836	51,458	56,429	61,398	67,497	4.0

iFLH-160000

H.Ex. Rows	Entering Water Temp.	3 GPM					W.P.D	4 GPM					W.P.D
		CFM						CFM					
		600	800	900	1000	1250	600	800	900	1000	1250		
4	120°F	24,625	27,865	29,865	31,087	34,211	3.7	28,268	30,042	31,986	34,109	38,287	5.7
	130°F	28,218	33,572	35,724	37,429	41,357	3.7	33,625	36,256	38,524	41,162	46,456	5.7
	140°F	32,865	39,218	41,625	43,843	48,379	3.7	38,245	42,367	45,412	48,235	53,971	5.5
	150°F	37,536	45,075	47,536	50,327	55,485	3.6	42,765	48,559	52,369	55,149	61,864	5.5
	160°F	42,125	50,732	53,425	56,798	62,632	3.6	47,325	54,632	58,489	62,268	69,832	5.4
	170°F	46,852	56,579	59,425	63,266	69,769	3.5	51,869	60,861	64,542	69,345	77,846	5.4
	180°F	51,425	62,329	65,325	69,747	76,982	3.5	56,465	67,054	72,369	76,486	85,742	5.3

iFLH-180000

H.Ex. Rows	Entering Water Temp.	3 GPM					W.P.D	4 GPM					W.P.D
		CFM						CFM					
		600	800	1000	1200	1450	600	800	1000	1200	1450		
4	120°F	28,963	34,245	35,648	38,946	42,376	5.6	30,125	36,203	38,224	42,376	46,638	6.9
	130°F	33,412	39,632	42,820	46,981	50,966	5.5	34,845	41,952	45,996	50,996	56,173	6.8
	140°F	37,954	45,126	50,157	54,844	59,632	5.5	39,652	47,623	53,756	59,465	65,789	6.7
	150°F	42,503	50,520	57,489	62,529	68,334	5.4	44,321	53,304	61,533	68,255	75,223	6.7
	160°F	47,127	55,963	64,732	70,931	77,065	5.3	49,032	59,123	69,325	76,905	84,896	6.6
	170°F	51,608	61,412	72,078	78,842	85,648	5.3	53,741	64,745	77,199	85,627	94,441	6.5
	180°F	56,129	66,846	79,354	87,055	94,633	5.2	58,429	70,487	84,923	94,336	104,056	6.4

i Installation

1) Location requirements and clearances:

- The installer shall comply with all local, state/provincial and national code requirements that apply to the installation of this equipment.
- The air handler must be installed in such a way that electrical components are protected from water during operation and service.
- If installed in an unconditioned space, sealant should be applied around where the electrical wires, refrigerant tubing, and condensate lines enter the cabinet. This appliance shall not be installed in a non-conditioned space where the potential may exist for the appliance, water lines and/or drain lines to freeze.
- If installed with air conditioning in a suspended application, ensure a drain pan with a proper slope is installed.

Recommended Clearances:

Be sure to provide a minimum of 24" clearance to the front panel of the iFLOW air handler. 0" clearance is allowed for all other sides of the cabinet and for the first 36" of ductwork. Ensure adequate clearance is left for the installation of ductwork, plumbing, and electrical connections.

2) Dimensions

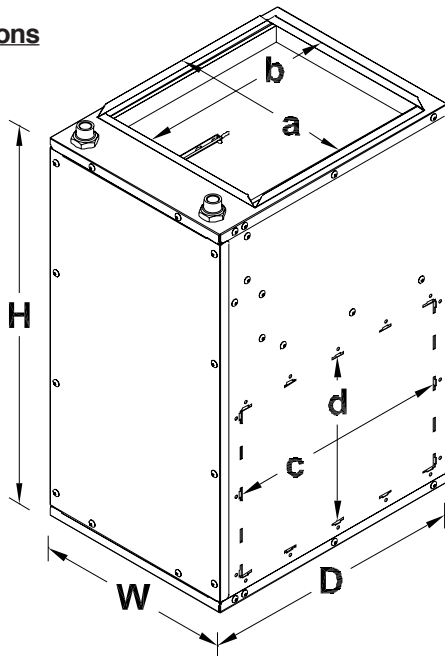

Example only

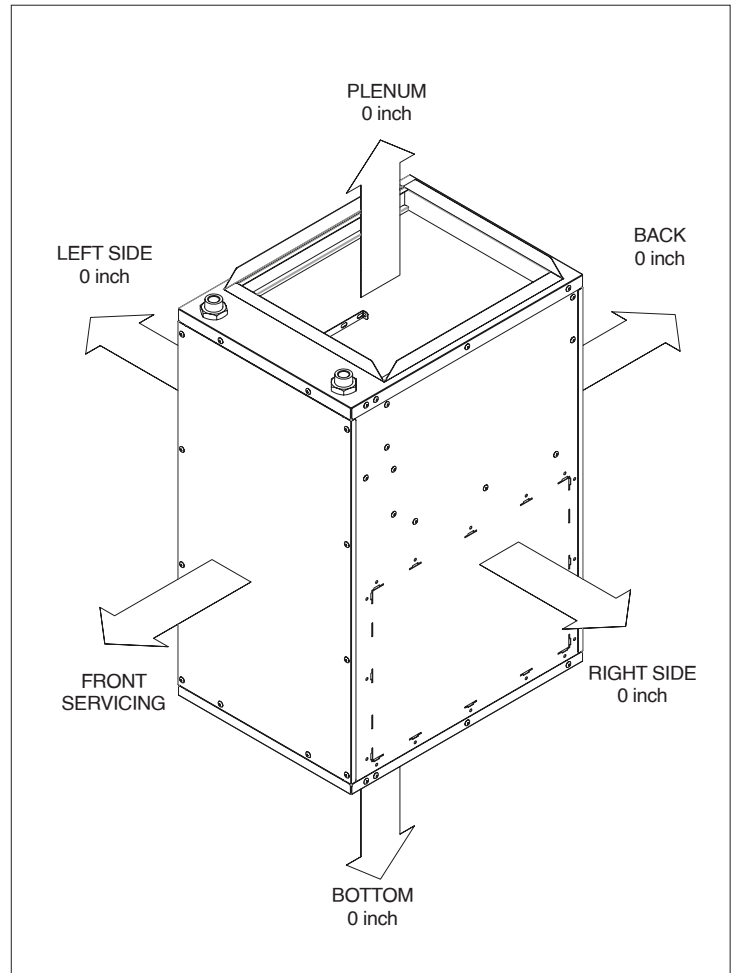

Model	Unit	Width	Depth	Height	a	b	c	d
14" Cabinet	in	14	18 3/4	27 1/8	13	14	16	12
	mm	355.6	476.3	689	330.2	355.6	406.4	304.8
16" Cabinet	in	16	20 3/4	27 1/8	14	16	18	13
	mm	406.4	527.1	689	355.6	406.4	457.2	330.2
18" Cabinet	in	18	25 3/4	29 1/8	16	20	23	14
	mm	457.2	654.1	739.8	406.4	508	584.2	355.6

3) Installation examples:

The iFLOW air handler is multi-positional and therefore can be mounted in any position. If installed with air conditioning, proper positioning of the evaporator coil and drain line must be considered to install correctly.

Vertical Installation

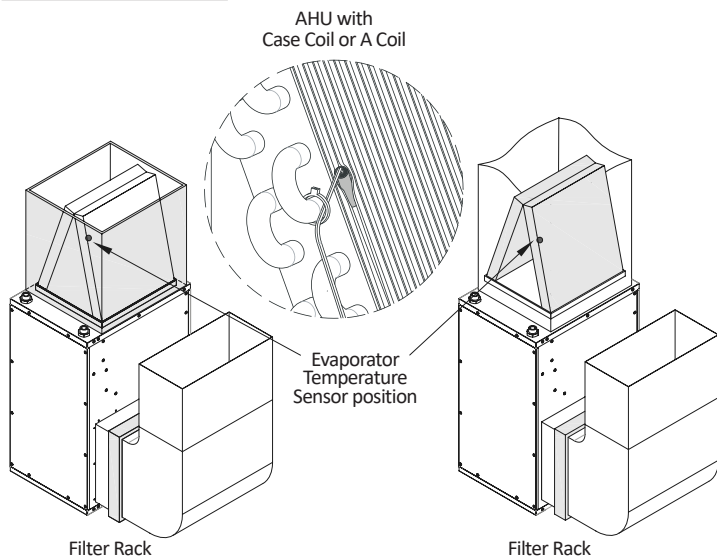

Horizontal Installation

The evaporator coil must be installed on the supply side of the air handler.

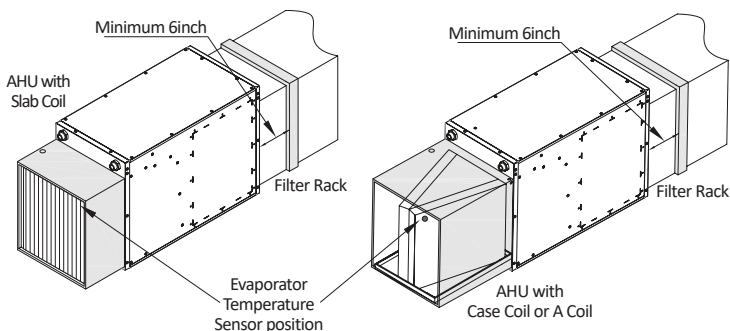

Hanging Installation

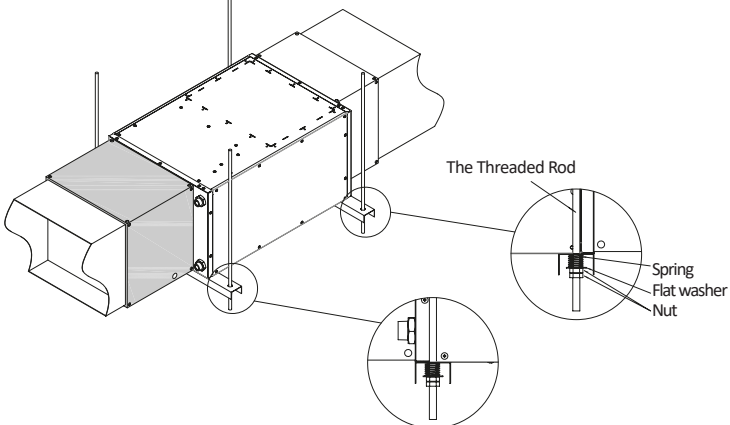

Ceiling Installation

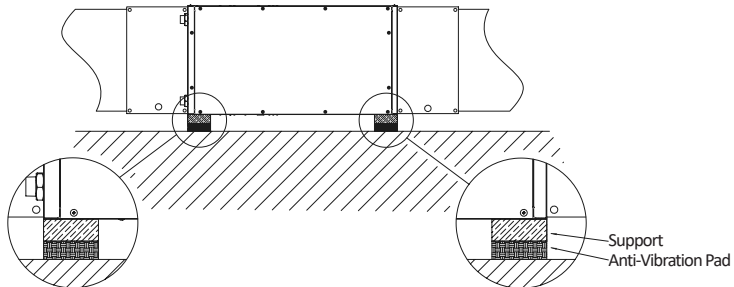

4) Water Heater / Boiler Piping:

When installing the iFLOW air handler with a heating boiler or combi-boiler in a closed loop system, refer to the boiler manufacturer's instructions for proper installation with an air handler. Depending on the boiler selected and system design, it may be required to use a primary/secondary piping arrangement to de-couple the flow through the boiler from the flow through the air handler.

Air-removal device:

Provisions shall be made for the removal of air in the heat-distribution piping system. The air-removal device shall be located in the area of the heat-distribution piping system where the air is likely to accumulate (often the highest point in the system).

Required Components:

Expansion tank, isolation valves, air eliminator, dirt collector/filter/strainer (if other heating loads are being heated by the same boiler), make-up water and low loss header (optional).

Sensor Installation

A/C Evaporator Temperature Sensor: **Air outlet on the Evaporator coil** (See Installation Illustration: Page 12)

Zone Air Temperature Sensor:

Zone supply side: Air outlet of the damper
Zone return side: Air inlet of the damper (if there is a dedicated return duct with the damper)

5) Domestic Piping:

Notes: When installing the iFLOW air handler with a water heater, refer to the manufacturer's guidelines on coupling the water heater with an air handler. Use components and piping that are allowable with potable use. Lead-free solder must be used on all joints. When both top and side connections are present on the water heater, the side connections should be used for the space-heating loop. The heating loop connections should be positioned horizontally in a vertical section of the domestic water line for both the inlet and outlet. Refer to the piping diagram for details. Minimize the distance and piping between the water heater and the iFLOW air handler. If the main water line has an installed check valve, a potable expansion tank must be installed to provide room for the expansion of water.

6) Installing the iFLOW air handler with a tankless/tank water heater:

Check with the tankless water heater manufacturer prior to installation to ensure it can be used for combo space heating applications. Make sure to check that the valves, including but not limited to the purge and isolation valves are properly installed. If connecting to a tankless water heater, the circulating pump needs to be sized correctly.

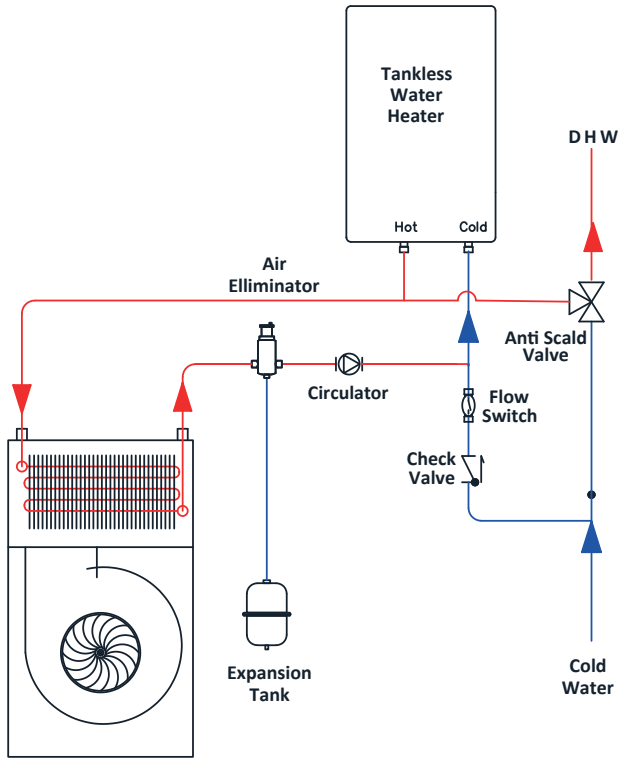

7) Electrical requirements and making connections:

This unit requires single phase AC 120V power to operate and must be hardwired. To connect, follow these directions:

1. To avoid electrical shock, turn off electrical power at the breaker dedicated to the air handler. Ensure the power remains off while any wiring connections are being made.
2. Remove the iFLOW front access panel.
3. Route the field supplied line voltage wiring to the iFLOW air handler.
4. Using CSA & UL listed wire nuts, connect the field supplied wires to the air handler (black to black and white to white).
5. Connect ground wire to GND terminal.
6. Repeat the process for the circulating pump (connect to terminal block).
7. Route low voltage thermostat wire to the unit; connect to thermostat terminal on control board.
8. Re-secure the front access panel.

8) Temperature sensors:

The iFLOW air handlers come equipped with 5 wire sensors that plug into connectors on the control board for easy servicing.

1. Supply water sensor: mounted on the supply end of the water heating coil.
2. Return water sensor: mounted on the return end of the water heating coil.
3. Supply air sensor: mounted above the water heating coil exchanger to detect supply air temperature and freezing temperatures.
4. Return air sensor: factory installed in return air path blower. If you install a slab coil on the return air side, you must install the return air sensor before(or upstream of) the slab coil.
5. Outdoor temperature sensor: modulates air handler operation based on outdoor temperature. Provides outdoor reset function.
6. A/C Evap sensor: mount on the A coil, or on the slab coil. It should be installed on the surface of the cold air outlet on the evaporator or the U-bend pipe. Refer to the figure below.

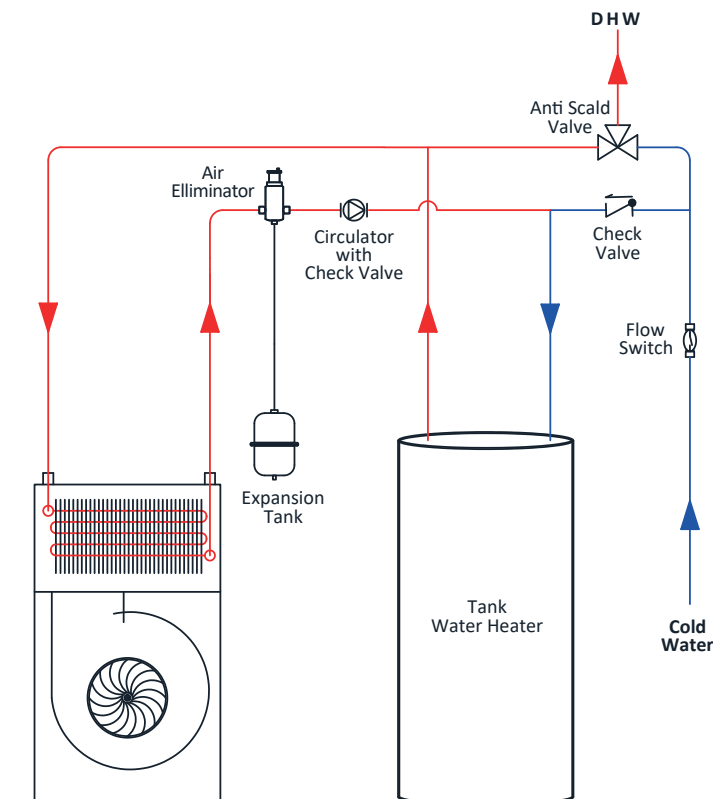
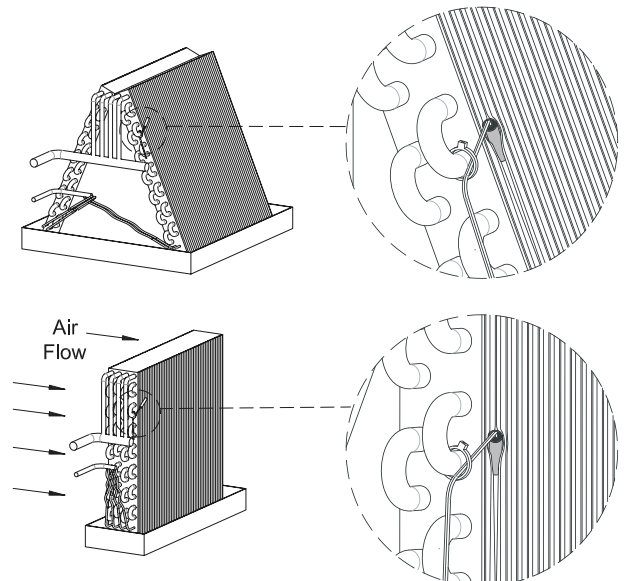

9) A/C Evaporator Coil Freeze Protection and the Importance of Wiring the A/C Compressor to the Proper and Dedicated A/C Connector on the iFLOW PCB:

The iFLOW Hydronic Furnace incorporates advanced freeze protection for your A/C evaporator coil. When the iFLOW A/C Evaporator temperature sensor sees an air temperature of 37°F (3°C) or below, the iFLOW will immediately interrupt the power supply to the A/C compressor for 5 minutes. It will however maintain the blower 'ON' to move air flow across the evaporator coil to warm it and to prevent freezing. When the iFLOW A/C Evaporator Temperature sensor sees a temperature of 45°F (7°C) or more than 3 minutes has expired since initial compressor interrupt, it will allow the compressor to begin again. There is a minimum off period of 3 minutes to prevent on/off damage to the compressor.

As such, when installed properly, there should be no concern about freezing the evaporator coil, damaging the A/C compressor nor freezing the hydronic coil with an iFLOW Hydronic Furnace. To ensure full protection however, you **MUST** follow the 2-Step installation explanation below:

Step 1

To ensure the iFLOW will be able to interrupt the A/C compressor when needed to protect the equipment, **the A/C compressor must be wired to the dedicated A/C terminal on the PCB** (see figures C-1 & C-2). The location on the PCB of this dedicated A/C connector varies by model; please consult the wiring diagram section of this installation manual for details.

The 24V output signal for the A/C compressor **MUST NOT BE CONNECTED** be connected to the thermostat connection on the PCB (see figure D). If the 24V signal for the A/C compressor is connected to the thermostat connection on the iFLOW PCB, the 24V signal will come from the thermostat and there is no way for the iFLOW to interrupt the compressor, thus you will have **NO A/C FREEZE PROTECTION**. In addition, there is a high likelihood of damage to the PCB and the hydronic coil. There will be **NO WARRANTY** for PCB damage nor freezing damage to the hydronic coil resulting from improper field wiring.

FIGURE D:

Incorrect Wiring:

**No A/C Evap Coil Freeze Protection;
No warranty for damaged PCB or freezing of the hydronic coil**

FIGURE C-1:

Correct Wiring:

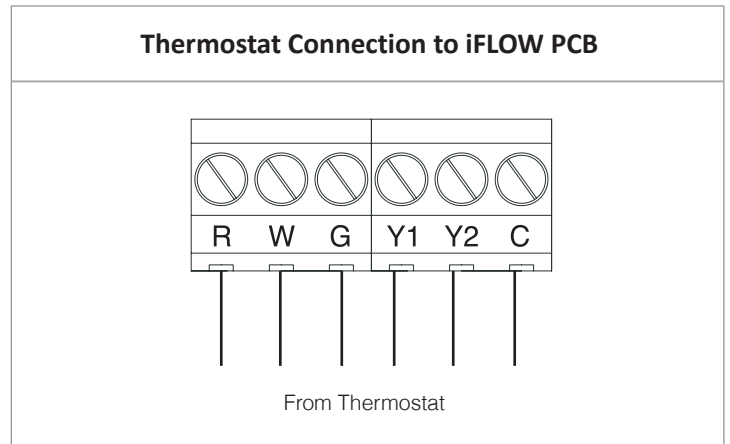
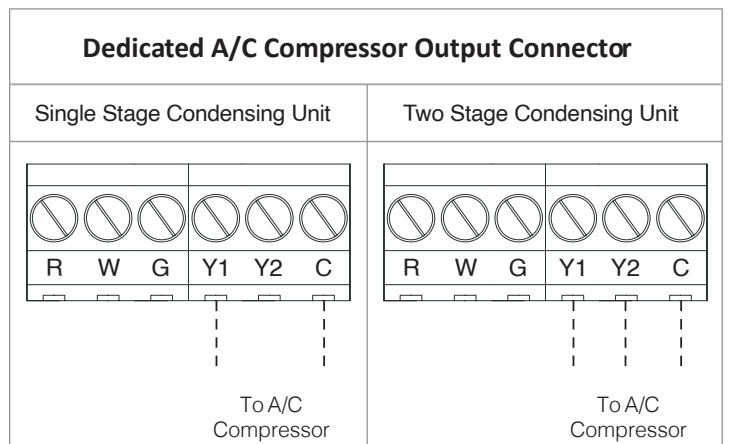

FIGURE C-2:

Correct Wiring:

**A/C compressor interrupt enabled
Location of connector may vary by model**



CAUTION

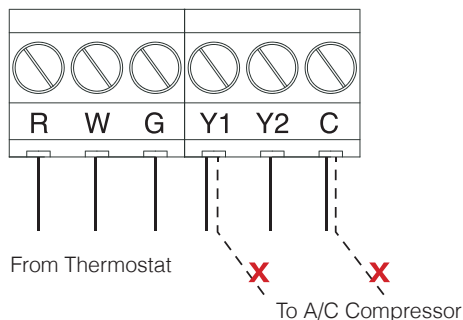

CAUTION
DO NOT DO!

Step 2

To ensure the iFLOW can protect the A/C evaporator coil from freezing up, iFLOW has an “A/C EVAP Temperature sensor” (part number: 30ETS01B) that must be attached to A/C coil in a way that it is able to sense the accurate air temperature coming directly off (downstream of) the A/C evaporator coil. Figure E below depicts the location of the A/C Evaporator Temperature sensor when using a cased coil or an A-coil in the supply duct and Figure F depicts the location of the A/C Evaporator Temperature sensor when using a slab coil in the return duct. In both cases, insert the sensor in between the fins on the coil.

FIGURE E:

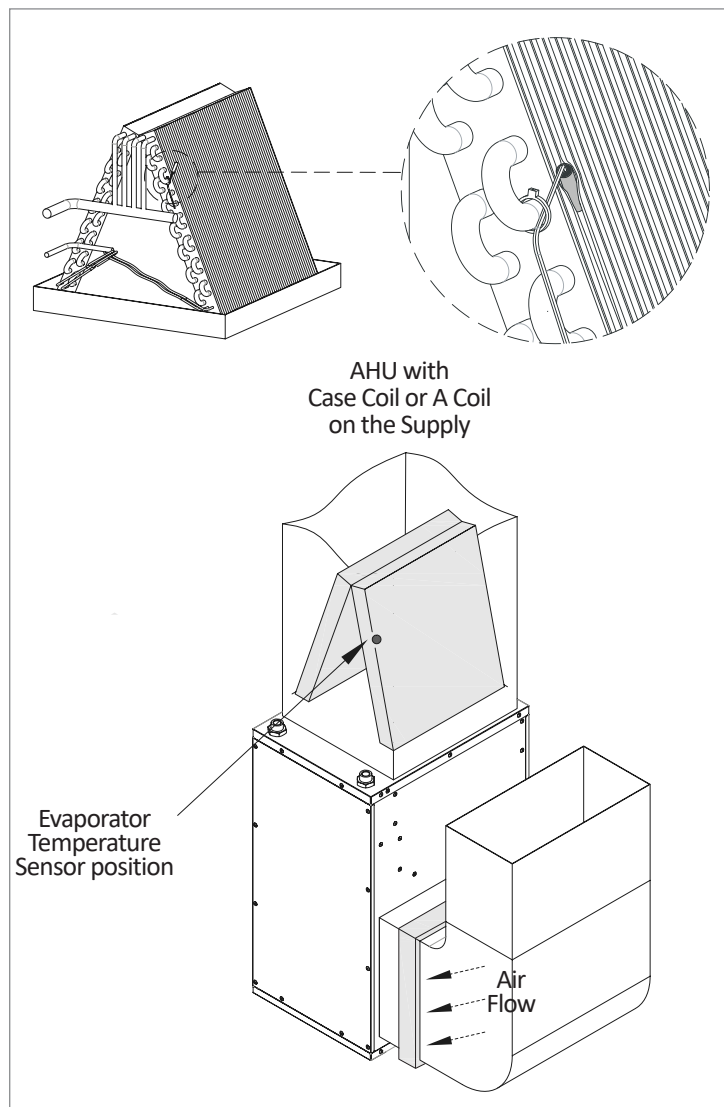
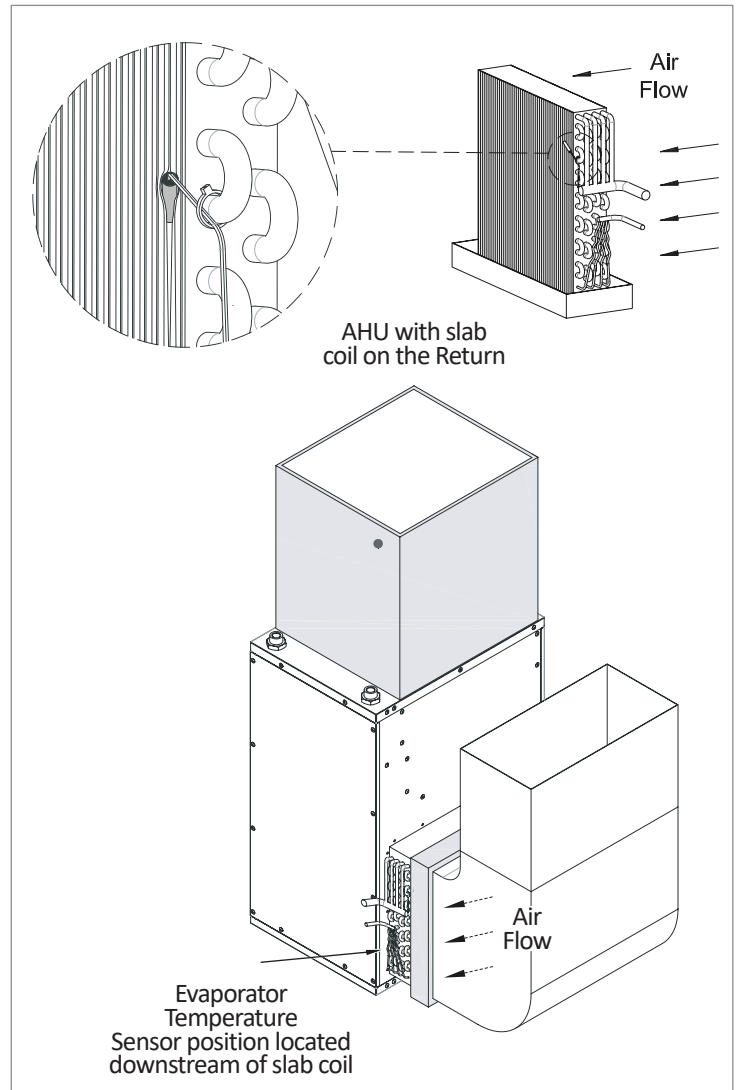

FIGURE F:



IMPORTANT

Position the sensor in the A-coil in the supply duct as shown above in Figure E. To relocate the A/C evaporator temperature sensor to a slab coil in the return duct, follow the following steps. From the factory, the sensor is placed loose on top of the hydronic coil. Follow the wire back towards the PCB and disconnect the sensor at the black male/female connector located between the sensor and the PCB. Gently push the sensor back through the rubber grommet; the sensor is now free. Relocate the sensor as shown above in Figure F. Once the sensor is relocated, reconnect the wire. If necessary, use any thermostat wire to extend the length of the sensor wire. When running the wire back to the original connector, ensure the wire runs around and not in front of the PCB and transformer.

The connection port on the iFLOW PCB for the A/C Evaporator Temperature sensor varies by model but is generally located near the top center of the PCB. Please consult the PCB schematic in the installation manual for details.

If steps 1 & 2 are followed, the iFLOW delivers A/C evaporator and hydronic coil freeze protection.

'Power Stealing / Robbing' Thermostats:

Some thermostats are considered "Power Stealing" or "Power Robbing". These are thermostats that have an internal rechargeable battery which should be recharged ideally from a dedicated 24V 'C' wire. In cases where there is no 'C' wire, these types of thermostats will 'steal' or 'rob' power from the 24V supplied by the 'R' wire. As soon as there is a power draw off this line, the iFLOW's very precise PCB design will recognize this as a call for heating and will immediately start, even though the thermostat is not calling for heating. It is the power draw for the battery recharge that is mimicking a call for heat.

This unexpected draw of power off the R line (or any 'field solution' attempted) may damage the PCB circuitry of the iFLOW over time, which would not be considered a 'manufacturer's defect' and thus would not be covered under warranty.

This is not an iFLOW issue, nor is this a thermostat issue. Thermostat manufacturers are trying to come up with creative solutions for retrofits to make their 5 wire thermostats (normally R, W, G, Y C), operate on fewer wires (so they can sell more thermostats of course). Those solutions however, are not always compatible with advanced electronics. At the end of the day however, the problem is the wiring in the home is not sufficient to properly operate a communicating thermostat.

There are a few of options:

- 1) Use iFLOW's Smart Mode and completely eliminate the thermostat (available on the iFLOW W, D and Q models);
- 2) Use either a simple AA or AAA powered thermostat; or
- 3) Rewire to provide at least 3 wires for heating (R, W, C) or at least 4 wires if also cooling (R, W, Y, C).

i START-UP

1) Procedure:

Do not start the boiler or water heater until ALL air has been purged from the water lines and air handler pump.

1. Fill the boiler loop or water heater with water. Do not start it.
2. Purge all air from the heating boiler or domestic hot water system (Hold the UP & ENTER button for 10 seconds and then the circulator will alternate power ON and OFF for about 10 minutes to purge air).
3. Purge all air from the space heating loop by closing the isolation valve on the return leg of the loop and open the drain to purge the air. Open the return leg isolation valve and then close the drain valve.
4. If a bleed screw is not present, it is recommended to run the pump on speed #3 for 1 minute. If air is still present, switch from speed #1 to #3 every 10 seconds for a minute.
5. Start the boiler or water heater according to the manufacturer's instructions. Set the design water temperature and wait for the system to satisfy and shut off.
6. Turn on the power to the iFLOW air handler and set the room thermostat to 'heat' to energize the fan and pump. If noise is still present after one minute, repeat step #3 to purge air.
7. Check supply and return pipes for temperature differences to make sure there is flow. There should be a noticeable difference in temperature. Use caution when supply water temperature is above 120° F.

2) Flushing the heat exchanger:

Flushing the hot water coil prior to startup is required to remove any residual material from the installation or manufacturing processes as well as to remove any air from the system. Take precautions while flushing the air handler to prevent the multi-function control board and other electrical components from getting wet.

The iFLOW air handler requires an external circulating pump to be installed and should be installed with an external purge valve.

Flushing is a 3-step process:

- 1) Use a bucket or hose to dispose of water during the flushing process. First, flush the return line by closing the inlet valve (supply) and opening the outlet valve (return). Open the purge valve. Close the purge valve once flushing is complete.
- 2) Second, flush the supply line and coil by closing the outlet valve (return) and opening the inlet valve (supply). Open the purge valve. Close the purge valve once flushing is complete.
- 3) Third, apply power to the air handler. Open inlet and outlet valves. Engage the pump and open the purge valve. Verify proper flow direction - inlet valve sh

3) Sequence of operation:

Cooling: When the thermostat calls for cooling, the circuit between R and G is completed. The normally open contacts close and the air handler blower motor operates. The circuit between R and Y is also completed; this closes the contact on the outdoor condenser unit. The air handler fan turns off 45 seconds after the call for cooling is completed.

Heating: When the thermostat calls for heat, the circuit between R and W is completed, activating the hot water circulating pump. A dry switching relay labeled "T" can be used to activate a boiler or combi boiler. After the circuit between R and W is completed, a time delay follows before the circuit between R and G is completed, which will then activate the air handler blower motor.

Freeze protection: If the temperature of the water in the hot water coil drops below 40°F/4°C, the circuit between R and W is completed. This will activate the circulating pump until the water temperature reaches 70°F.

Pump timer/ exercise function: The iFLOW control is equipped to turn on the circulating pump to cycle the total volume of potable water in the system if the pump has not been turned on within the past 12 hours. This function is skipped while the A/C condensing unit is operating.

How to Access and Configure the iFLOW Intelligent Controller

The controller has 4 modes:

1. Information	3. Parameters
2. Error Codes	4. Test Mode

The controller has 4 buttons used to navigate those modes:

MODE: Press the 'MODE' button to scroll between the different modes, numbered 1-6 (see above).

ENT: Press the 'ENT' (enter) button to confirm the mode you wish to enter. Press 'enter' to also confirm any changes or commands that you selected using the 'up' and 'down' buttons (see below) while in each mode.

UP & DN: Once you are in a 'mode', press the 'UP' and 'DN' (down) buttons to scroll all menu lists of the various information.

Information Mode

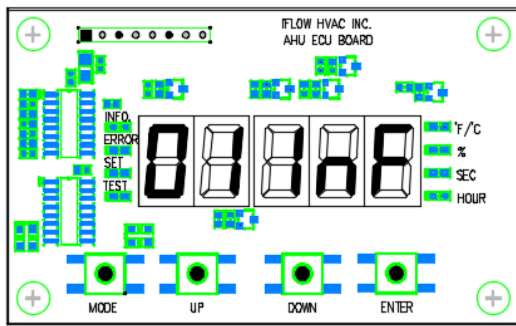

How to access Information display:

Push the mode button until the screen reads **01nf**. Press enter to confirm the information mode. Use the up and down buttons to see the different information unavailable from number 01-19. The 3 characters on the right and side will indicate the value. If the sensor is not installed, 999 will be displayed.

Display	Description	Explanation
01030	Blower Motor Speed	Indicates present operation as a percentage of the total fan motor CFM capacity
02045	Circulator Speed	Indicates the percentage of the total GPM of the circulator
03037	Water Temperature Δt (Delta T)	Indicates the difference between the supply and return water temperature in °F
04043	Air Temperature Δt (Delta T)	Indicates the difference between the supply and return air temperature in °F
05004	Outdoor Temperature	Displays the outdoor air emperature in °F.
06139	Supply Water Temperature	Displays the temperature of the water entering the hydronic coil heat exchanger, in °F
07102	Return Water Temperature	Displays the temperature of the water exiting the hydronic coil heat exchanger, in °F
08104	Supply Air Temperature	the temperature of the air exiting the air handler into the plenum, in °F
09072	Return Air Temperature	Displays the temperature of the air entering the air handler from the return duct, in °F

Display	Description	Explanation
10036	A/C Evaporator emperature	Displays the current temperature of the air sensor attached downstream of, but near the evaporator coil in °F
11038	Dehumidifier Evaporator Temperature	Displays the current temperature of the sensor located in the dehumidifier evaporator, in °F
12046	Humidity Value	Measured value of the current humidity in the return section of the unit
13001	Flow Switch On/Off State	Indicates whether the external flow switch, which is wired to the control board, is activated or not (ON = flow; OFF= no flow)
140FF	Circulator Relay State	Indicates whether the external field supplied circulator is in operation (ON = should be operating; OFF= should not be operating)
1500FF	Boiler TT State	Indicates whether the air handler is currently sending a dry contact call for heat to the connected boiler (ON = calling boiler on; OFF= not calling boiler on)
160FF	A/C Relay State	Indicates whether the air handler is sending an AC 24V call to the condensing unit
170FF	Dehumidifier Relay State	Indicates whether the Dehumidifier is in the on or off condition.
180FF	Humidifier Relay State	Indicates whether the external humidifier which is wired to the c ontrol board is in on or off condition

Error Mode

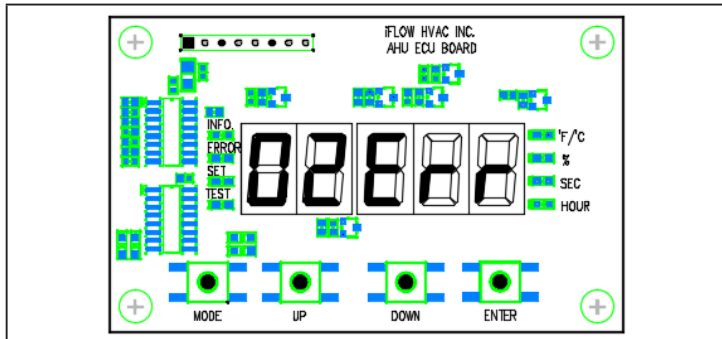

How to access Error codes:

Push the mode button until the screen reads **02 Err**. Press enter to confirm the Error code mode. Use the up and down buttons to see the last 10 errors which will be numbered 01 to 10, with 01 being the most recent. The 3 numbers on the righthand side will indicate which error code is present. If more than 10 errors occur, the oldest error will be deleted from the memory.

Display	Description	Explanation
01:01		
02:02		
03:04		
04:07		
05:08		
EXAMPLE OF LAST 10 ERROR CODES		
06:10		
07:11		
08:12		
09:20		
10:41		

Parameter Settings Mode

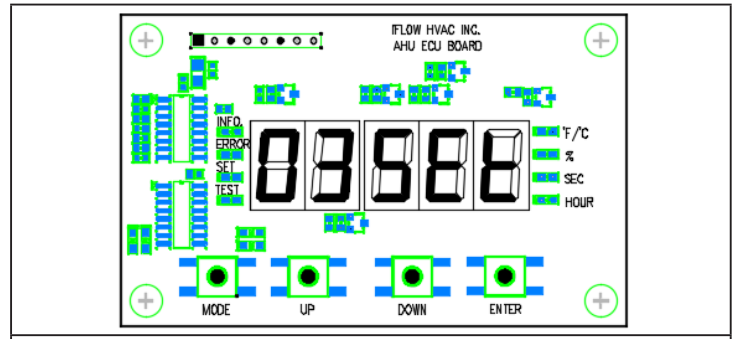

How to Parameters settings:

Push the mode button until the screen reads **03 SET**. Press enter to confirm the Parameters mode. The screen will show the first parameter 01. Use the up and down buttons to choose which parameter to be changed from number 01-28 and press enter. The 3 characters on the righthand side will indicate the value. Use the up and down buttons to change the range of the value and press enter to confirm and mode to exit.

Item	Display	Range	Default
Fan Min. Speed (Heat)	01:20	10 - 25	20
Fan Max. Speed (Heat)	02:30	25 - 100	30
Pump Min. Speed (Heat)	03:45	40 - 60	45
Pump Max. Speed (Heat)	04:70	60 - 100	70
Blower Motor Speed @ G Mode	05:10	5 - 30	10
Y1 Blower Motor Speed	06:55	20 - 65	55
Determines the Y1 cooling mode of the blower motor operation after a call for cool occurs.			
Y2 Blower Motor Speed	07:80	65 - 90	80
Determines the Y2 cooling mode of the blower motor operation after a call for cool occurs.			
Lowest Outdoor Temperature	08:05	0°F - 32°F	5°F
Min. HeatLoss	09:20	6 - 30 KBTU/h	20K
Max. HeatLoss	10:90	15 - 100 KBTU/h	60/70/90
Determines the desired maximum BTUH output that is required.			

Item	Display	Range	Default
Hybrid Mode	11000	0=Diable, 1=Enable	0
0 : Hot Water Only (water heater, boiler or combi-boiler) 1: Hot Water + heat pump (Hybrid)			
H/P Cut-Off Temp.	12040	32 ~ 46°F (0 ~ 8°C)	40
Set the lowest temperature at which you wish the heat pump to operate (Balance Point Consideration: H/P COP and cost of electricity at that temperature vs. gas efficiency and cost of gas). Below that temperature, iFLOW will switch to the gas hot water source.			

Test Mode

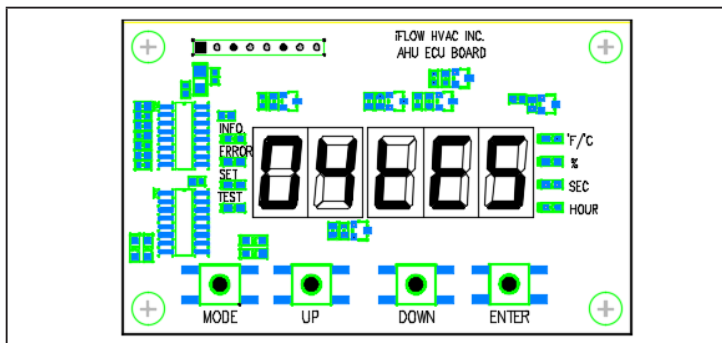

How to access Test codes:
Push the mode button until the screen reads **04 tES**. Press enter to confirm the test mode. Use the up and down buttons to choose the test number 01-9. Each test will be explained below.

Description	Display	Test Operation
Blower Motor Speed Test	010FF	0 - 100%
Press enter while 01 is flashing. Display will flash 0. use arrows to change value from 0-100% blower speed. Blower will speed up and down simultaneously as you increase or decrease the value.		
Circulator Speed Control	02000	30 - 100%
Press enter while 02 is flashing. Display will flash 0. use arrows to change value from 0-100% circulator speed. Circulator will speed up and down simultaneously as you increase or decrease the value.		
Relay Output	Circulator Relay	030FF AC 24V
Press enter while 03 is flashing. Display will show OFF. Use up or down to turn on. Relay test will start immediately. Press enter to exit.		

Description	Display	Test Operation
Boier TT Relay	040FF	ON / OFF
Press enter while 04 is flashing. Display will show OFF. Use up or down to turn on. Boiler TT Relay will start immediately. Press enter to exit.		
OPT	050FF	
Reserved		
Dehumidifier Relay	060FF	ON / OFF
Press enter while 06 is flashing. Display will show OFF. Use up or down to turn on. Dehumidifier Relay Test will start immediately. Press enter to exit.		
Humidifier Relay	070FF	ON / OFF
Press enter while 07 is flashing. Display will show OFF. Use up or down to turn on. Humidifier Relay Test will start immediately. Press enter to exit.		
Flow Switch	080FF	ON / OFF
Press enter while 08 is flashing. Jumper terminals Flow Switch on right hand side of control board. The display will flash ON if it is working correctly. Also you may turn the hot water tap on if connected to a tankless water heater for the same.		
Y1 Relay	090FF	ON / OFF
Press enter while 09 is flashing. Display will show OFF. Use up or down to turn on. Y1 Relay will start immediately. Press enter to exit.		
Y2 Relay	100FF	ON / OFF
Press enter while 10 is flashing. Display will show OFF. Use up or down to turn on. Y2 Relay will start immediately. Press enter to exit.		
B Relay	110FF	ON / OFF
Press enter while 11 is flashing. Display will show OFF. Use up or down to turn on. B Relay will start immediately. Press enter to exit.		
O Relay	120FF	ON / OFF
Press enter while 12 is flashing. Display will show OFF. Use up or down to turn on. O Relay will start immediately. Press enter to exit.		

i Service and Maintenance

1) Maintenance:

At the beginning of each season, the air handler should be serviced by a qualified installer or service technician.

- **Filter:** This filter should be inspected and replaced as required.
- **Coils:** the heating and air conditioning coils should not require regular maintenance IF a regular filter maintenance schedule is followed. In the event, the filter is damaged or plugged and dust has fouled the coil, replace the filter and carefully vacuum the heating and/or A/C coil.
- **Circulator:** The circulating pump is water lubricated and should not require regular maintenance. The system control has a pump exercise function during prolonged periods of no heat to avoid seizing.
- **Blower:** The blower requires regular cleaning due to the build-up of dust. In the event the filter is damaged, refer page 52 ~ 53 for disassembly.

2) Checking Temperature Sensors:

1. Remove cables from the temperature sensor.
2. Check the sensor resistance and compare the actual values with the curve on the chart.
3. Replacement of a sensor is required in the case of severe deviation.

Water Temp. Sensor Chart

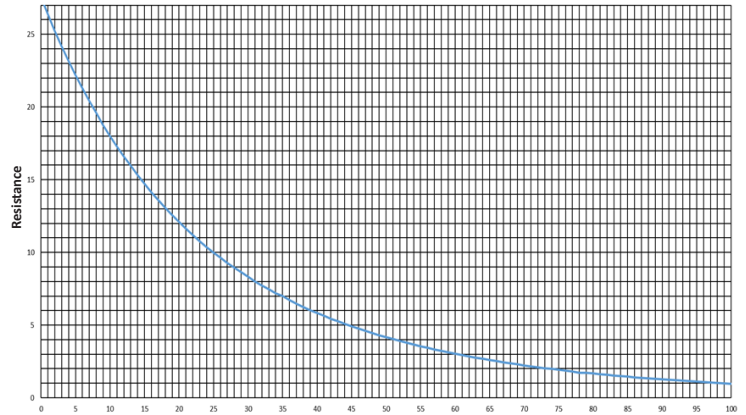

Evap. Temperature Sensor

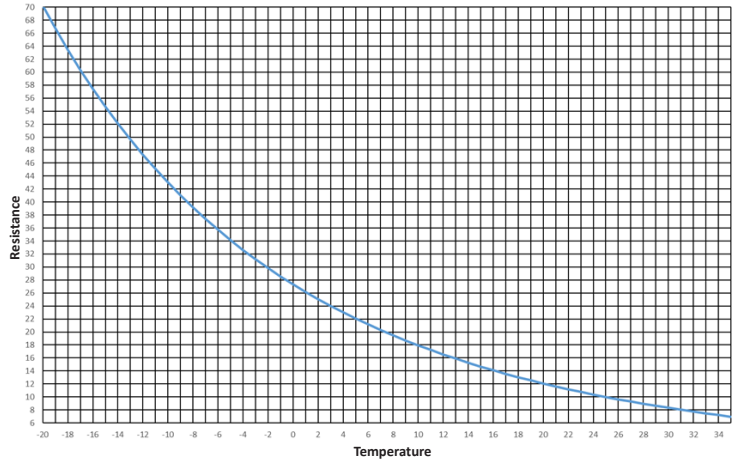

Outdoor Temp. Sensor Chart

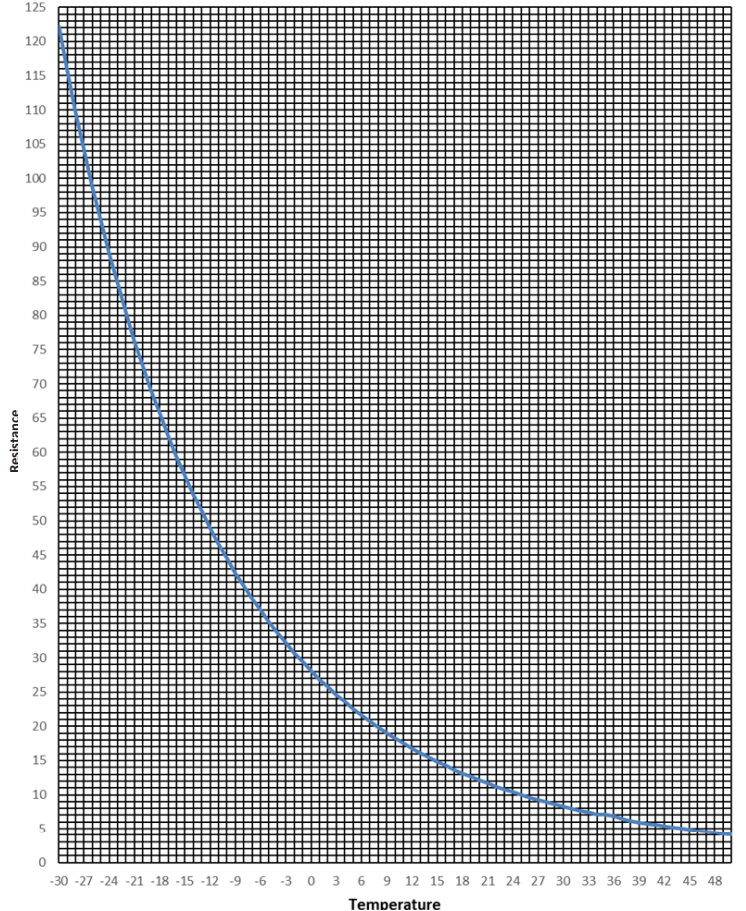

WIRING DIAGRAM

3) Field Installation Wiring Diagram

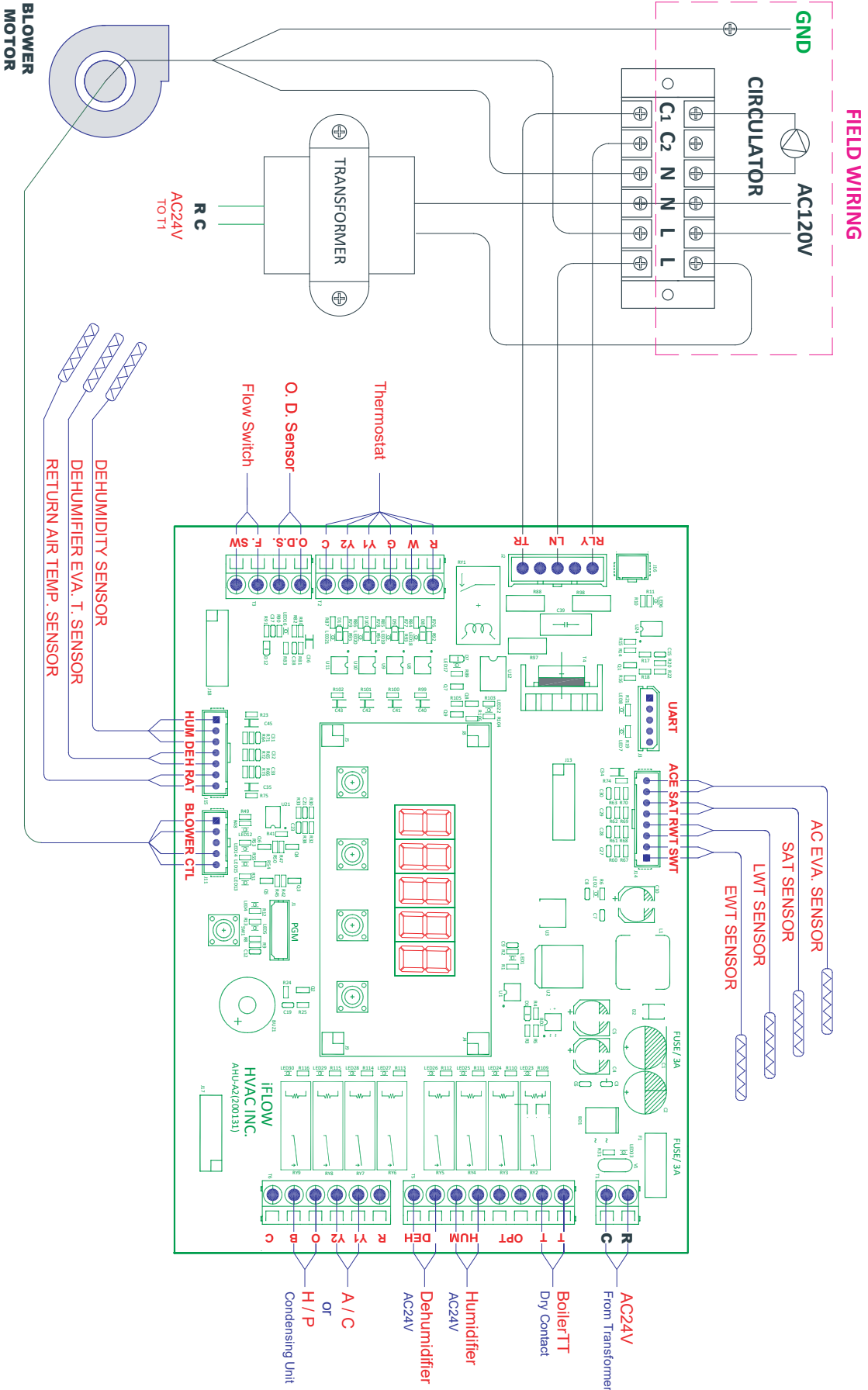

*** Do Not Connect A/C on Thermostat Connector ***

LEGEND / L: LINE/HOT N: NEUTRAL G: GROUND C1: CIRCULATOR SPEED CONTROL C2: CIRCULATOR RELAY CONTROL

4) A2 Field Wiring

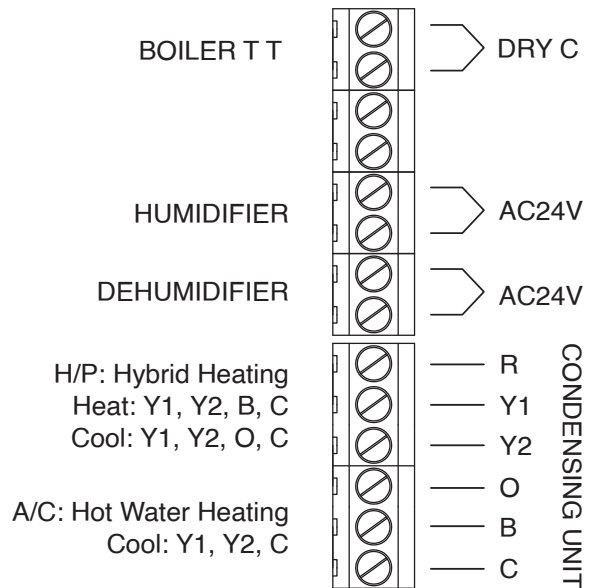
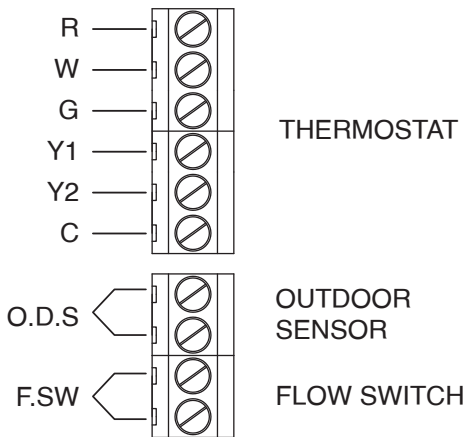
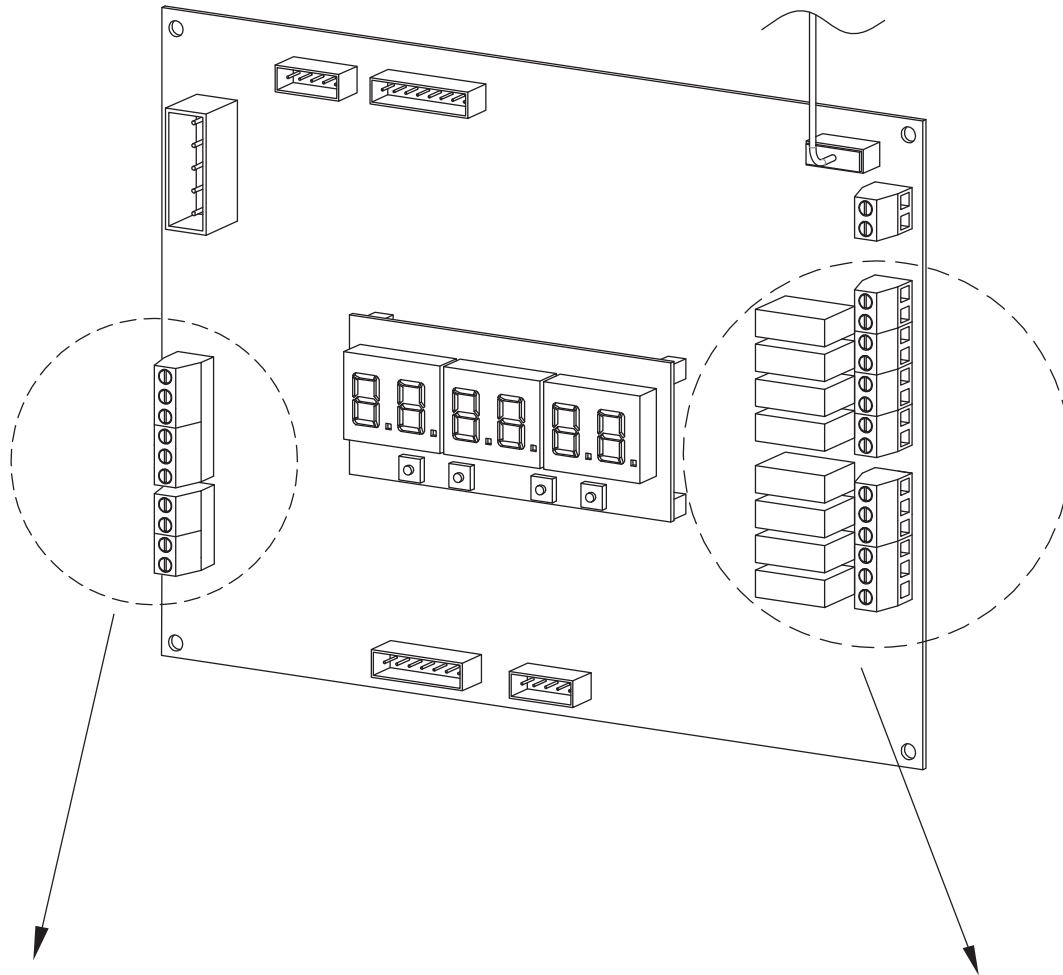

5) iFLOW Set up and Wiring of an iFLOW with a Heat Pump

When using an iFLOW with a Heat Pump, the iFLOW can toggle heating sources between the refrigerant-based, electric heat pump and the hot water-based system (a tankless or tank-type water heater, a combi-boiler, or a boiler for example). The homeowner gets the benefit of being able to select the most efficient and/or the most economical system; unfortunately however, both sources cannot run simultaneously.

So how does a homeowner decide which system to operate at which time of the heating season? That is a more involved question and beyond the scope of this document. What is fact however is this: as the outdoor temperature drops, especially below freezing, the heating capacity and the efficiency of heat pumps drop as well. As such, iFLOW uses an outdoor temperature sensor to determine the switchover point. The iFLOW outdoor temperature sensor is part # 30OTS01A. Alternatively, if using an iFLOW Wi-Fi enabled unit, the outdoor temperature can be sourced by geo-location.

To setup this functionality, the iFLOW needs to know the heating will be supplied by 2 sources, the hot water-based system, and the heat pump. iFLOW calls this 'Hybrid Mode'. To set Hybrid mode, adjust Mode 3, Parameter# 11 to '1' (it is default set at '0').

Parameter Settings Mode

Item	Display	Range	Default
Hybrid Mode	11000	0=Diable, 1=Enable	0
0 : Hot Water Only (water heater, boiler or combi-boiler) 1: Hot Water + heat pump (Hybrid)			
H/P Cut-Off Temp.	12040	32 ~ 46°F (0 ~ 8°C)	40

Set the lowest temperature at which you wish the heat pump to operate (Balance Point Consideration: H/P COP and cost of electricity at that temperature vs. gas efficiency and cost of gas). Below that temperature, iFLOW will switch to the gas hot water source.

At Mode 3/Parameter 12, the homeowner sets the temperature at which they wish to switchover (default is 40°F/0°C) from heat pump to water-based heating. On a call for heat from the thermostat, if the actual outdoor temperature is above the set switchover temperature, iFLOW will operate the heat pump for heating. If below, iFLOW will draw from the water-based heat source by calling on the circulator for heating. Please reference the installation manual on how to access these modes and parameters or see the excerpt above.

If your electric utility provider has 'peak rate' periods, the homeowner can choose not to run the electric heat pump during those specific peak periods, avoiding peak electricity rates. Those are set at Mode 4/Parameters 14~17.

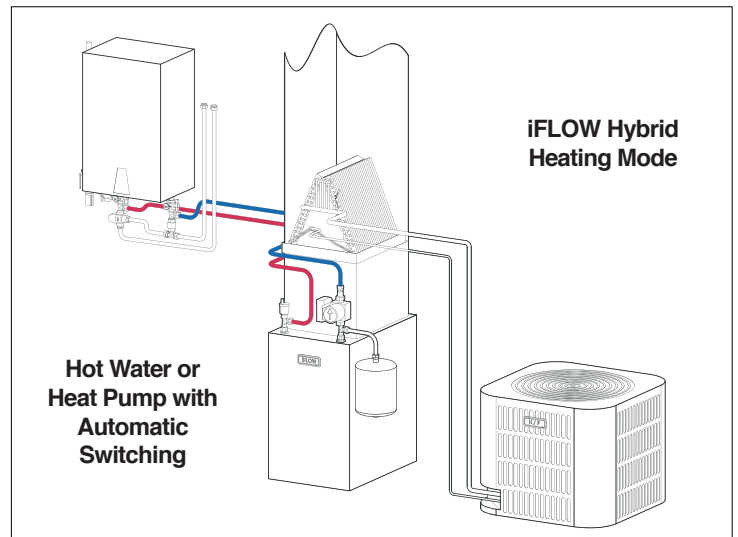
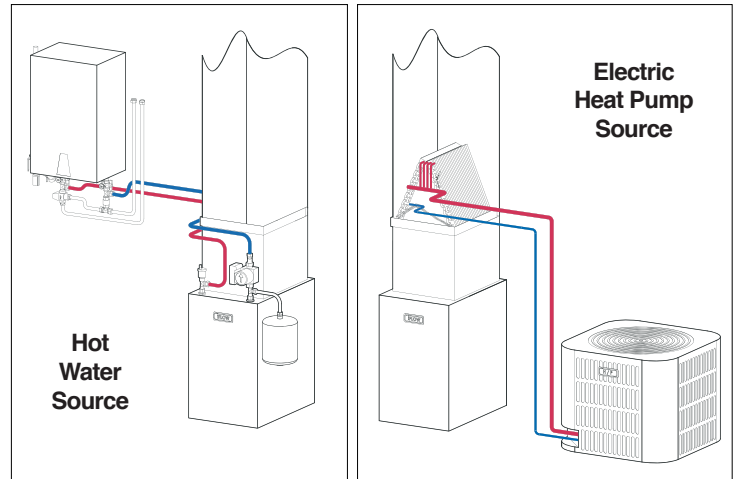

iFLOW D. H. Evaporator Temperature Sensor:

The installer must field supply and install the optional iFLOW D.H. Evaporator Temperature Sensor (part number 30ETS02B) and install it on the suction line of the heat pump. iFLOW uses this D.H. Evaporator Temperature Sensor to detect the operational state of the reversing valve. It must be installed for the system to operate. It is installed on the suction line, close to the evaporator (see diagram to the right).

iFLOW expects the majority of installations will not be paired with a heat pump, thus this sensor is not included as a standard item unfortunately.

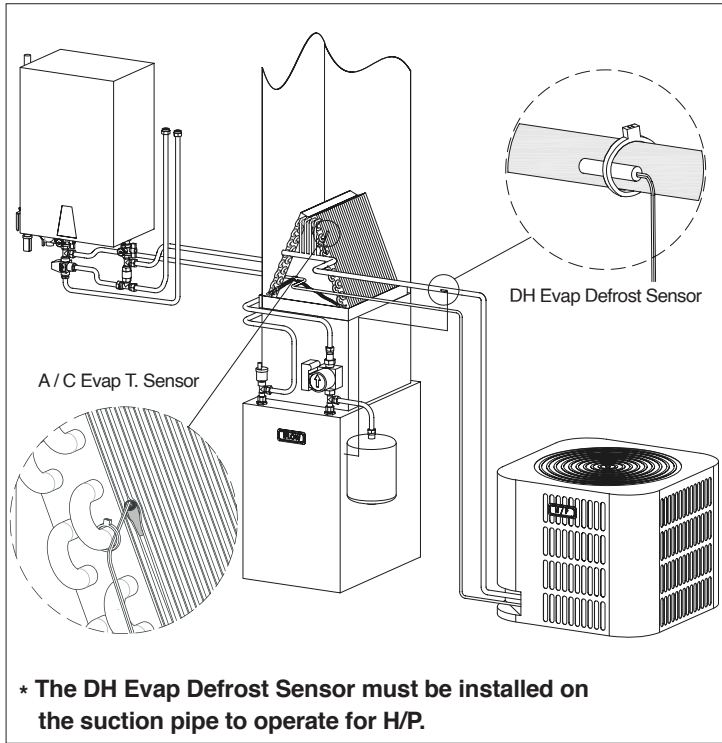

Type of Thermostats:

When pairing a heat pump with an iFLOW Hydronic Furnace, you DO NOT NEED any special or proprietary heat pump thermostat. iFLOW provides full functionality even with a basic thermostat; all iFLOW needs is R, W, G, & Y for full performance. iFLOW does not require staging, auxiliary, emergency or backup functionality from the thermostat, thus multiple thermostat contacts like W2, Y2, O, B, E, Em, Aux, etc. will not be used when connecting to the iFLOW.

CAUTION

Thermostat/iFLOW/Heat Pump Wiring:

Unfortunately it seems there is no wiring standardization within the heat pump industry. As most heat pumps are imported to North America, variances may occur by country of origin. Overall operation will be similar but detailed specifics will vary and as such, iFLOW cannot definitively assist with wiring diagrams. iFLOW will provide guidelines as 'suggestions' but DO NOT assume these are correct as they can vary by heat pump manufacturer.

When installing an iFLOW with a heat pump, Y is not considered a call for 'cooling'; it is considered a call for the 'compressor on'. **The installer must know whether the heat pump's default mode is heating or cooling. If unsure, simply call for 'compressor on' by jumping C and Y at the iFLOW PCB thermostat connection and then observe what temperature is being delivered to the evaporator: if hot, 'Heating' is the default mode; if cold, then 'Cooling' is the default mode.**

To what terminal on the heat pump and whether that terminal connection is marked (**O or B**), can vary by manufacturer. As such, the installing contractor **MUST NOT** rely solely on wiring diagrams without also confirming proper operation. To confirm operation, initiate a call for cooling and then feel the temperature on the heat pump line set to the evaporator to confirm chilled refrigerant. Next, initiate a call for heating to the heat pump. If wired correctly, heated refrigerant should have arriving at the evaporator coil. Be sure to confirm operation both heating and cooling to ensure no damage to the equipment.

CAUTION

Mistaking the wiring and not confirming both the heat pump's heating and cooling operation may lead to evaporator and hydronic coil damage that will not be covered under warranty

Given the variances, the installing contractor will have to coordinate the wiring between the products. All iFLOW can do is explain how its units will perform. As such, the wiring diagrams and directions below are provided as examples only and **may or may not** represent the heat pump being installed.

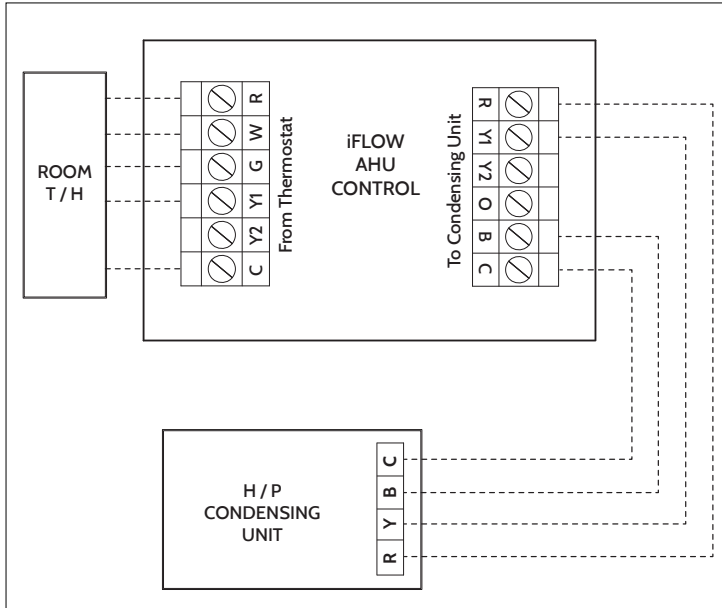

If the Heat Pump's **default mode is 'Heating'**, then:

- **On a call for heating**, the iFLOW will energize (24VAC output) Y1 and Y2 at the dedicated output contact (not at thermostat connection) to call the compressor on. The heat pump will deliver heating.
- **On a call for cooling**, the iFLOW will energize (24VAC output) Y1, Y2 and B at the dedicated output contact (not at thermostat connection) to call the compressor 'on' and to activate the reversing valve respectively. The heat pump will deliver cooling.

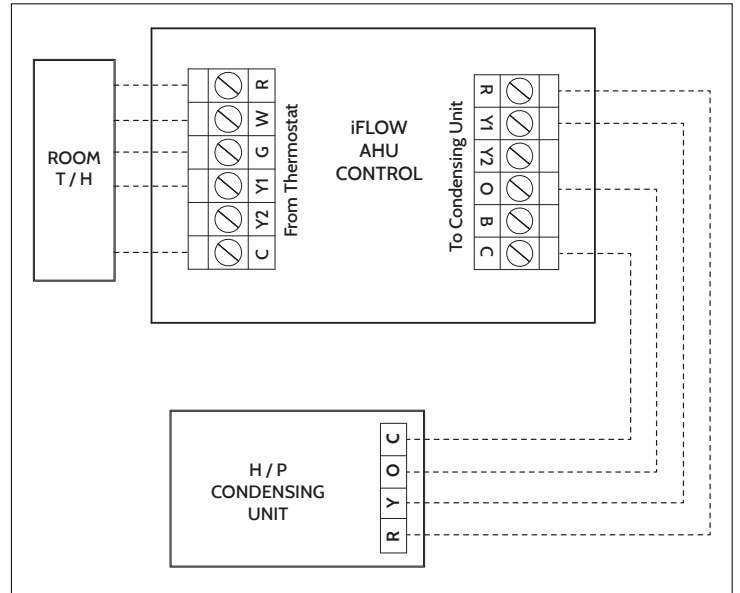

If the Heat Pump's **default mode is 'Cooling'**, then:

- **On a call for cooling**, the iFLOW will energize (24VAC output) at Y1, Y2 at the dedicated output contact (not at thermostat connection) to call the compressor on. The heat pump will deliver cooling.
- **On a call for heating**, the iFLOW will energize (24VAC output) Y1, Y2 and O at the dedicated output contact (not at thermostat connection) to call the compressor 'on' and to activate the reversing valve respectively. The heat pump will deliver heating.

Notes

- The signal for the reversing valve will come directly from the iFLOW to the Heat pump; as such, do not connect anything to the O and B contacts **at the thermostat**; they can be ignored
- If the actual outdoor temperature is below the "Heat Pump Heating Off" switchover temperature setting, the iFLOW will automatically call on the pump to use the water based heat source (and will not operate the heat pump).

If you encounter any set up difficulties, please contact iFLOW at 1-800-985-9227. Thank you for installing iFLOW Hydronic Furnaces. It is very much appreciated!

i Troubleshooting

1) Fault codes and Explanations:

Segment	Code	Description	Cause	
Sensor	001	Supply Air Temp. Sensor	Sensor has no continuity. Sensor is out of measuring range. Faulty Sensor.	Check sensor reading against corresponding temperature sensor chart. If out of range, replace sensor.
	002	Return Air Temp. Sensor		
	003	Supply Water Temp. Sensor		
	004	Return Water Temp. Sensor		
	005	A/C Evap. Temp. Sensor		
	006	D.H. Evap. Temp. Sensor		
	007	Outdoor Temp. Sensor		
	008	Humidity Sensor		
Heat Exchanger	020	H/ex. Freeze protection	Ambient temperature below 36°F	Unit will automatically run circulator until temperature is increased.
	021	H/ex Overheating	Water temperature delta t below 3°F	Ensure proper CFM, GPM. Make sure no restriction of water flow and airflow. Check sensor. Replace if necessary. Check filter. Check pump operation.
A/C Evaporator	030	A/C Evap. Freeze protection	Evaporator temperature below 37°F	check airflow. Check refrigerant level. Check proper A/C operation.
	031	A/C Evap. Overheating	Air temperature delta t below 5°F	Excessive cfm. Ensure proper A/C operation
D.H. Evaporator	040	D.H. Evap. Freeze protection	Evaporator temperature below 37°F	
	041	D.H. Evap. Overheat	Air temperature delta t below 5°F	
Water Flow	060	Abnormal Pump Operation	Improper pump size. Improper piping. Pump failure. Air in circulator. Check proper voltage and connection to circulator.	Ensure all causes are absent. If so, replace circulator.
Safety	070	Incorrect wiring	Incorrect thermostat/control wiring	Ensure all connections and tight and secure.
	080	Over Cooling	Return air temperature below 60.8°F during cooling mode	Run blower fan until temperature returns to normal operating conditions.
	081	Over Heating	Return air temperature above 80°F during heating mode	
	082	Room Temp. High	Return air temperature above 80°F before a call for heating	
	083	Room Temp. Low	Return air temperature below 60.8°F before a call for cooling	

2) Problem and Solutions

Insufficient or no heat:

- Filter or coil may be dirty. Refer to maintenance section for filter replacement and coil cleaning.
- Air trapped in the heating loop. Purge system.
- Inlet and outlet connections to air handler are backward. Reverse connections.
- Supply temperature is set too low. Check the water temperature.
- There is a restriction in the heating loop. Remove restriction. The check valve may be stuck. Valves may be too restrictive or left partially closed after purging.

Pump does not run:

Close the isolation valve on the return leg and open the drain port so that water flows through the pump; this may free the pump. The circulator may allow you to remove the front screw-on plate and rotate the shaft one turn with a slotted screwdriver. If either method fails to free the pump, removal for cleaning or replacement is necessary. The pump exercise function will help prevent pump seizing.

Pump is noisy at start-up:

Air is present in the loop. If the noise has not diminished after 1 minute, purge air in accordance with start-up procedure.

Fan runs for cooling but not for heating:

Check thermostat connections or thermostat. Check A/C condensing unit.

Heating during standby mode:

Probable cause is thermal syphoning. See check valve description for details. Repair or replace the check valve.

Freeze Protection:

This feature is initiated by extremely low air temperatures and is detected by the ambient air sensor.

Water Coil freeze protection:

This feature is initiated by extremely low air temperatures crossing over the freeze protection sensor located above the hydronic heating coil.

Cooling Lockout:

This feature is initiated after three freeze protection cycles occur within a single cooling cycle, or if three freeze cycles occur when a cooling cycle is not in progress. A freeze protection cycle is when the air handler A/C coil freeze sensor is triggered by unacceptably low discharge air temperature.

3) Component Assembly Diagram and Parts Lists

Assemble Diagram

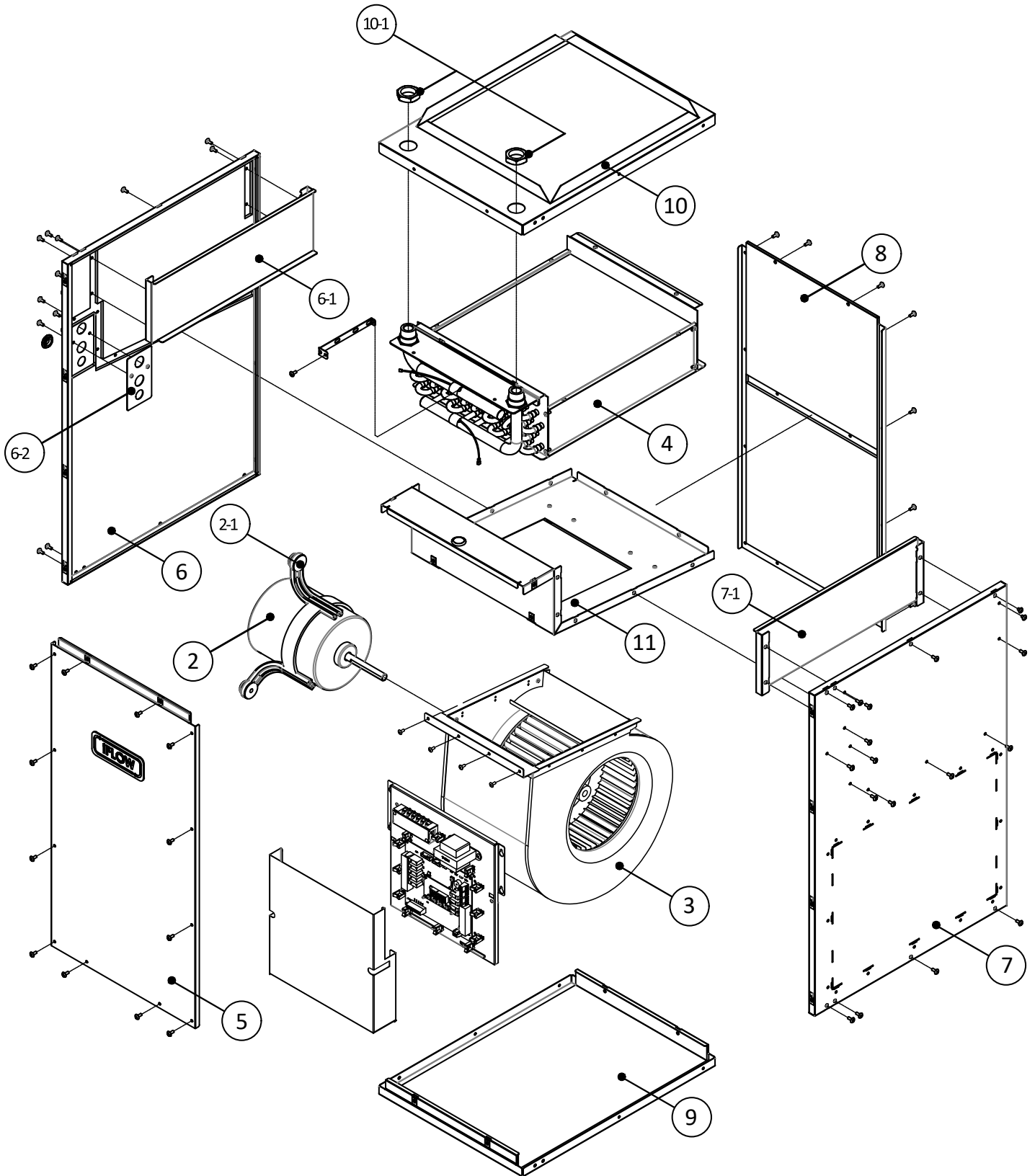

No	Description	Part #	Model	Service Parts	Remark
1	CTL Board Assembly	30CBA0SC	iFLH-14 / 16 / 180000	✓	
2	Blower Motor	2016121A	iFLH-14,160000	✓	
		2018341A	iFLH-180000	✓	
2-1	Motor Bracket Set	2014008B	iFLH-14 / 160000	✓	
		2018084B	iFLH-180000	✓	
3	Blower Assembly	201408CW	iFLH-140000	✓	DC-916-600-5CW
		201609CW	iFLH-160000	✓	DC-916-704-5CW
		201810CW	iFLH-180000	✓	DC-1020-800-5CW
4	Heat Exchanger	1014004A	iFLH-140000	✓	
		1016004A	iFLH-160000	✓	
		1018004A	iFLH-180000	✓	
5	Front Cover	0014FC00A	iFLH-140000		
		0016FC00A	iFLH-160000		
		0018FC00A	iFLH-180000		
6	Left Panel	0014LC00A	iFLH-140000		
		0016LC00A	iFLH-160000		
		0018LC00A	iFLH-180000		
6-1	Left Panel Heat Exchange Guide	0014LG00A	iFLH-140000		
		0016LG00A	iFLH-160000		
		0018LG00A	iFLH-180000		
6-2	Left Panel Hole Support	0000LS00A	iFLH-14 / 16 / 180000		
7	Right Panel	0014RC11A	iFLH-140000		
		0016RC11A	iFLH-160000		
		0018RC11A	iFLH-180000		
7-1	Right Panel Heat Exchange Guide	0014RG00A	iFLH-140000		
		0016RG00A	iFLH-160000		
		0018RG00A	iFLH-180000		
8	Rear Cover	0014RC00A	iFLH-140000		
		0016RC00A	iFLH-160000		
		0018RC00A	iFLH-180000		
9	Bottom Plate	0014BC00A	iFLH-140000		
		0016BC00A	iFLH-160000		
		0018BC00A	iFLH-180000		
10	Top Plate	0014TC00A	iFLH-140000		
		0016TC00A	iFLH-160000		
		0018TC00A	iFLH-180000		
10-1	Heat Exchange Pipe Nut	0000HN00A	iFLH-14 / 16 / 180000		
11	Middle Frame	0014MF00A	iFLH-140000		
		0016MF00A	iFLH-160000		
		0018MF00A	iFLH-180000		

Cabinet Diagram

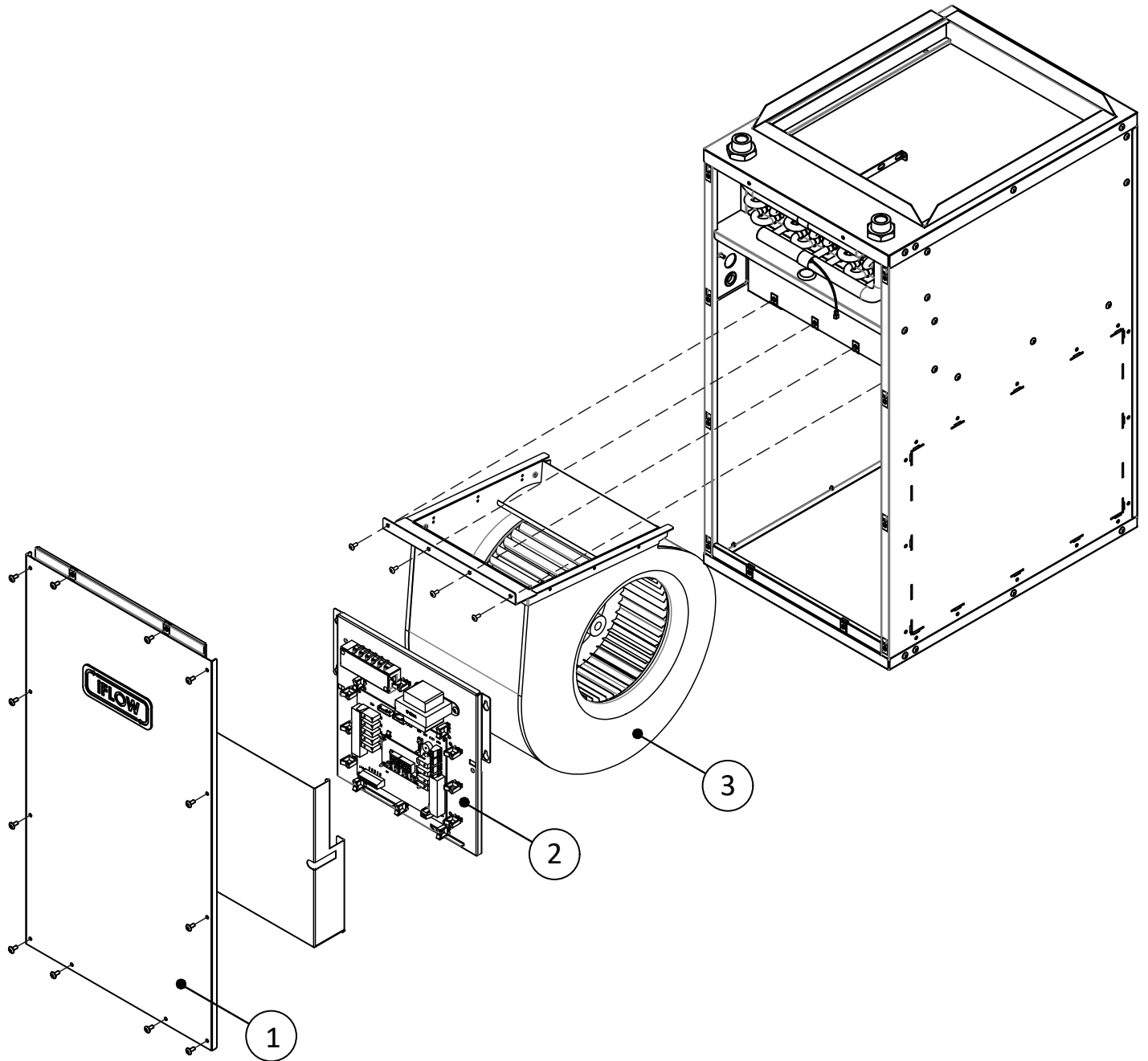

No	Description	Part #	Model	Remark
1	Front Cover	0014FC00A	iFLH-140000	
		0016FC00A	iFLH-160000	
		0018FC00A	iFLH-180000	
2	CTL Board Assembly	30CBA0SC	iFLH-140000	
			iFLH-160000	
			iFLH-180000	
3	Blower Assembly	201408CW	iFLH-140000	DC-916-600-5CW
		201609CW	iFLH-160000	DC-916-704-5CW
		201810CW	iFLH-180000	DC-1020-800-5CW

Blow Assembly

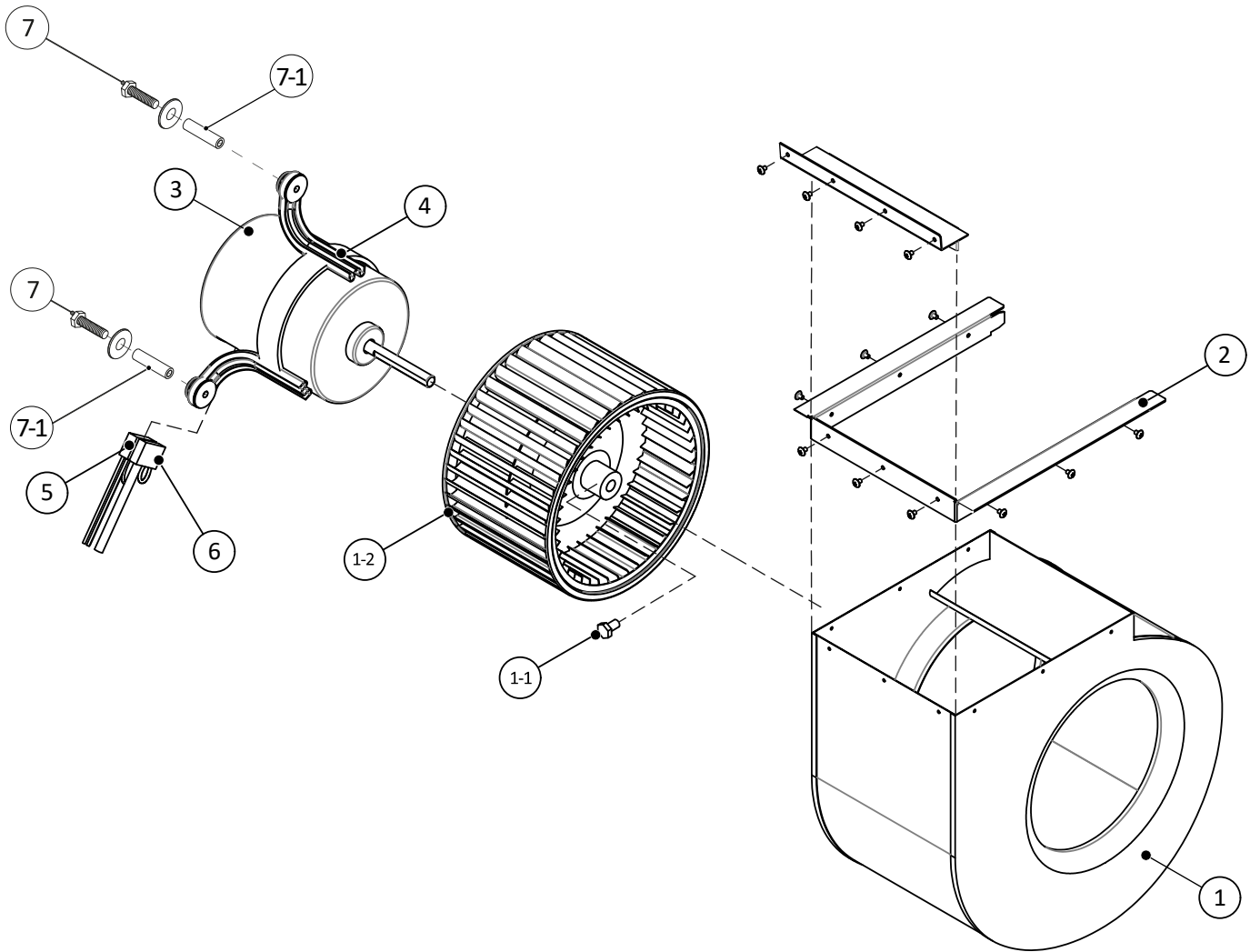

No	Description	Part #	Model	Remark
1	Blower Assembly Case	201408BC		
		201608BC		
		201808BC		
1-1	Blower Assembly Wheel Bolt	2000WB0A		
1-2	Blower Assembly Fan	201408BF		
		201608BF		
		201808BF		
2	Blower Assembly Bracket	2014081B	iFLH-140000	
		2016091B	iFLH-160000	
		2018101B	iFLH-180000	
3	Blower Motor	2016121A	iFLH-14,160000	
		2018341A	iFLH-180000	
4	Motor Bracket	2014008B	iFLH-14,160000	TR4803B
		2018084B	iFLH-180000	TR6884B
5	Motor CTL Cable	50MCTL1A		
6	Motor Power Cable	50121EON		
7	1/4"x1" Hex Cap Screw	50MBHCSA		

Heat Exchanger Assembly

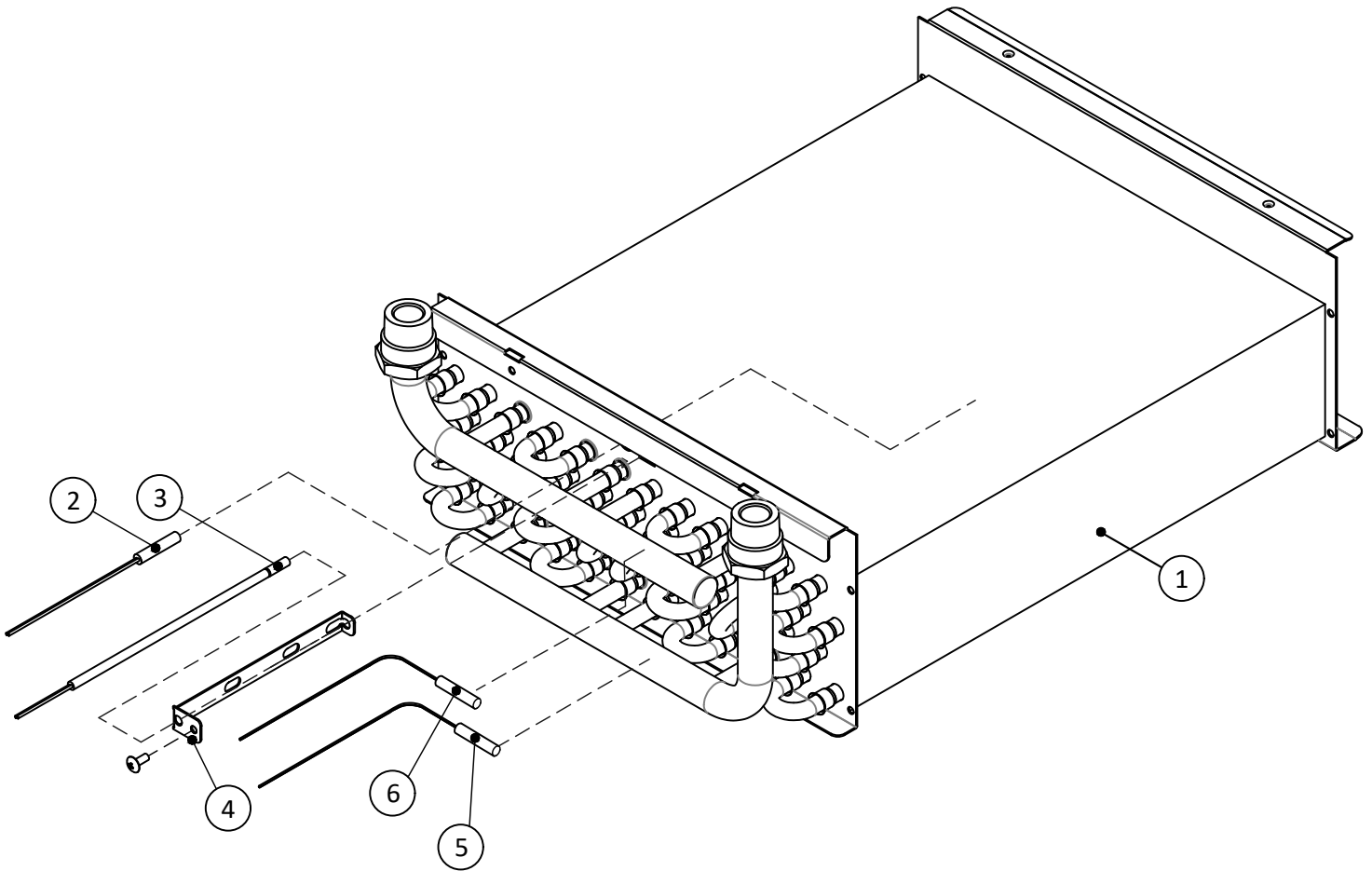

No	Description	Part #	Model	Remark
1	Heat Exchanger	1014004A	iFLH-140000	
		1016004A	iFLH-160000	
		1018004A	iFLH-180000	
2	A/C Eva. Temp. Sensor	30ETS01B		
3	Air Supply Temp. Sensor	30ATS01B		
4	Air Supply Temp. Sensor Bracket	30ATB00A		
5	Water Return Temp. Sensor	30WTR01C		
6	Water Supply Temp. Sensor	30WTS01C		

AHU with Tankless Water Heater Hybrid Space Heating Application

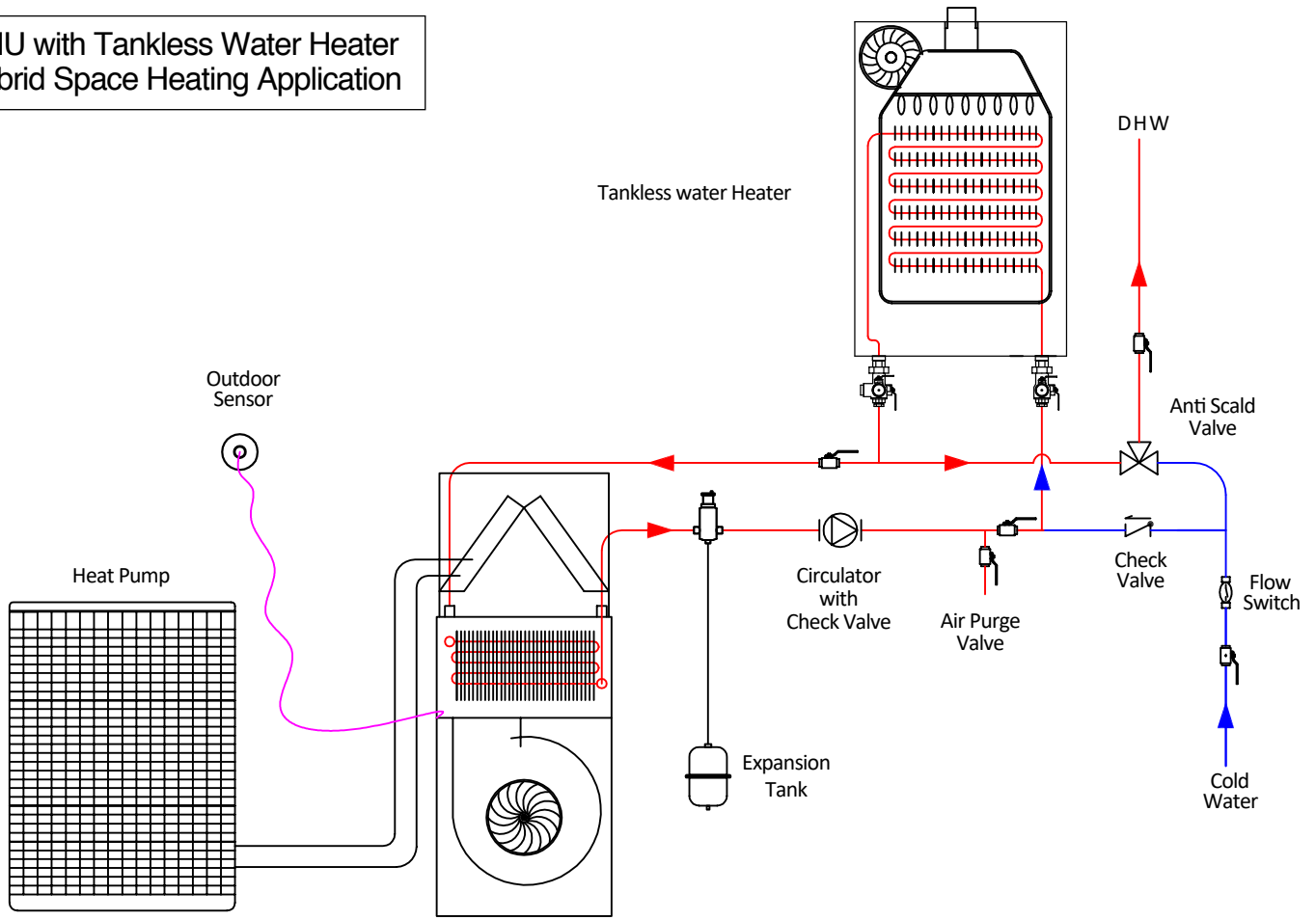

AHU with Tank Water Heater Hybrid Space Heating Application

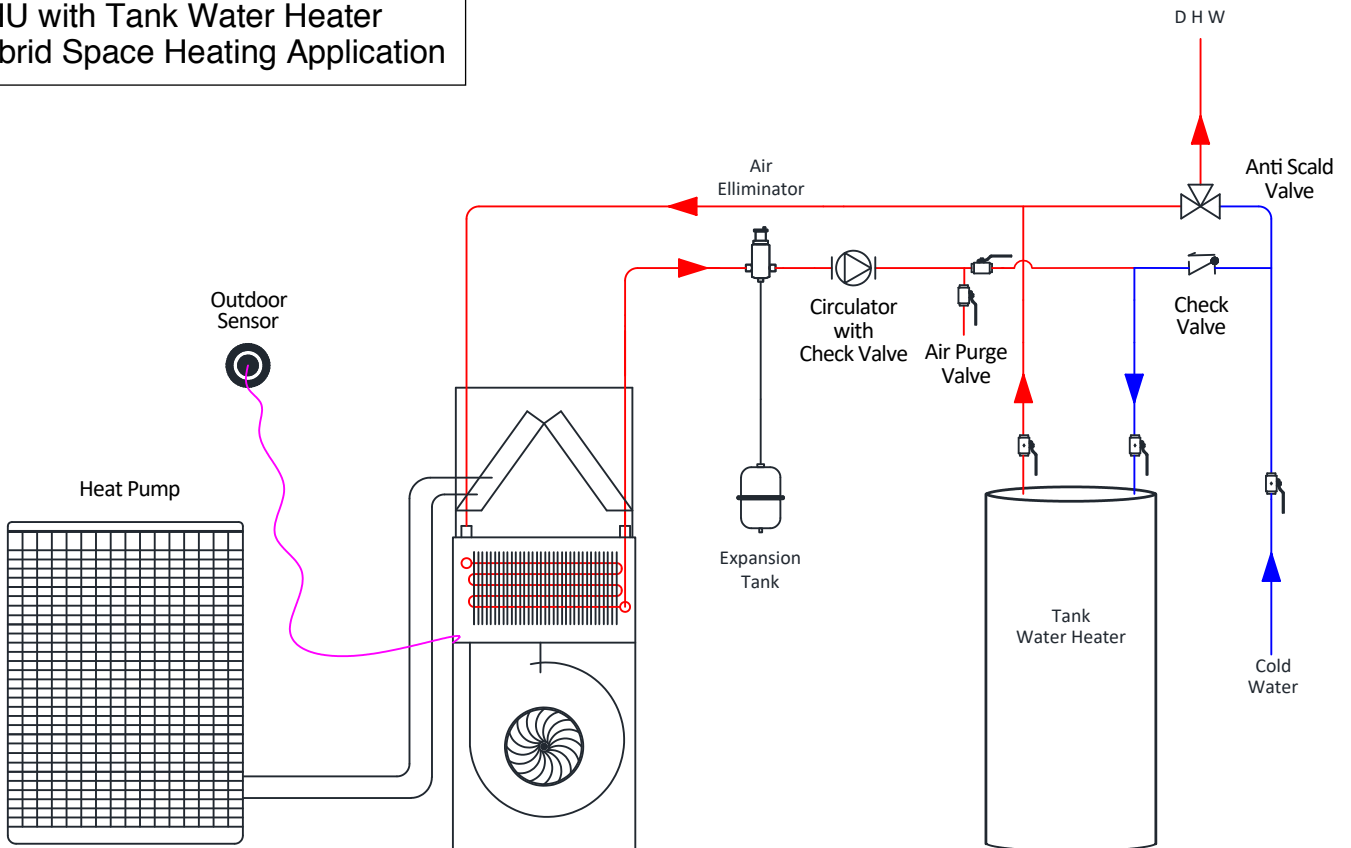

AHU with Tankless Water Heater
Space Heating Application

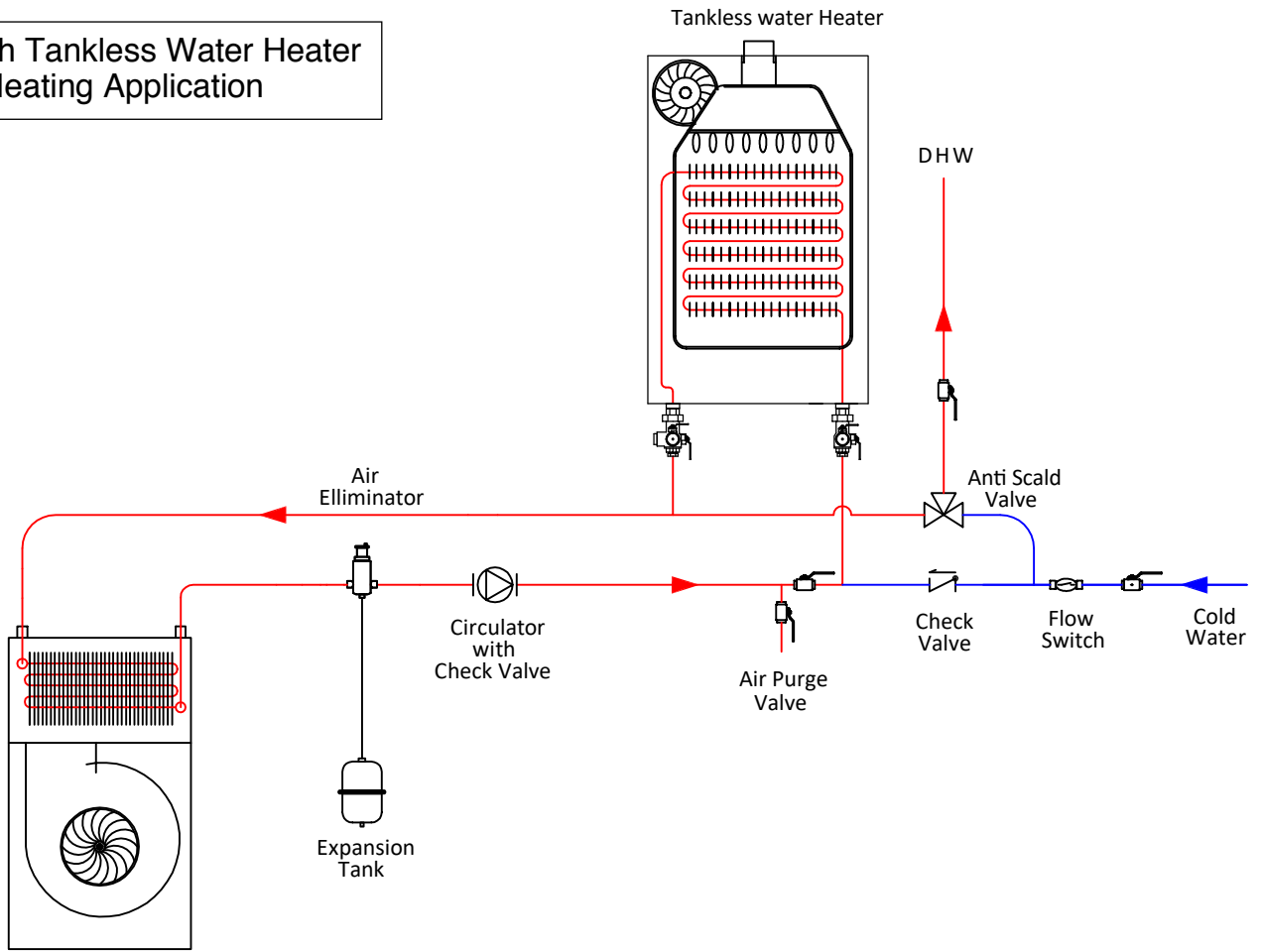

AHU with Tank Water Heater
Space Heating Application

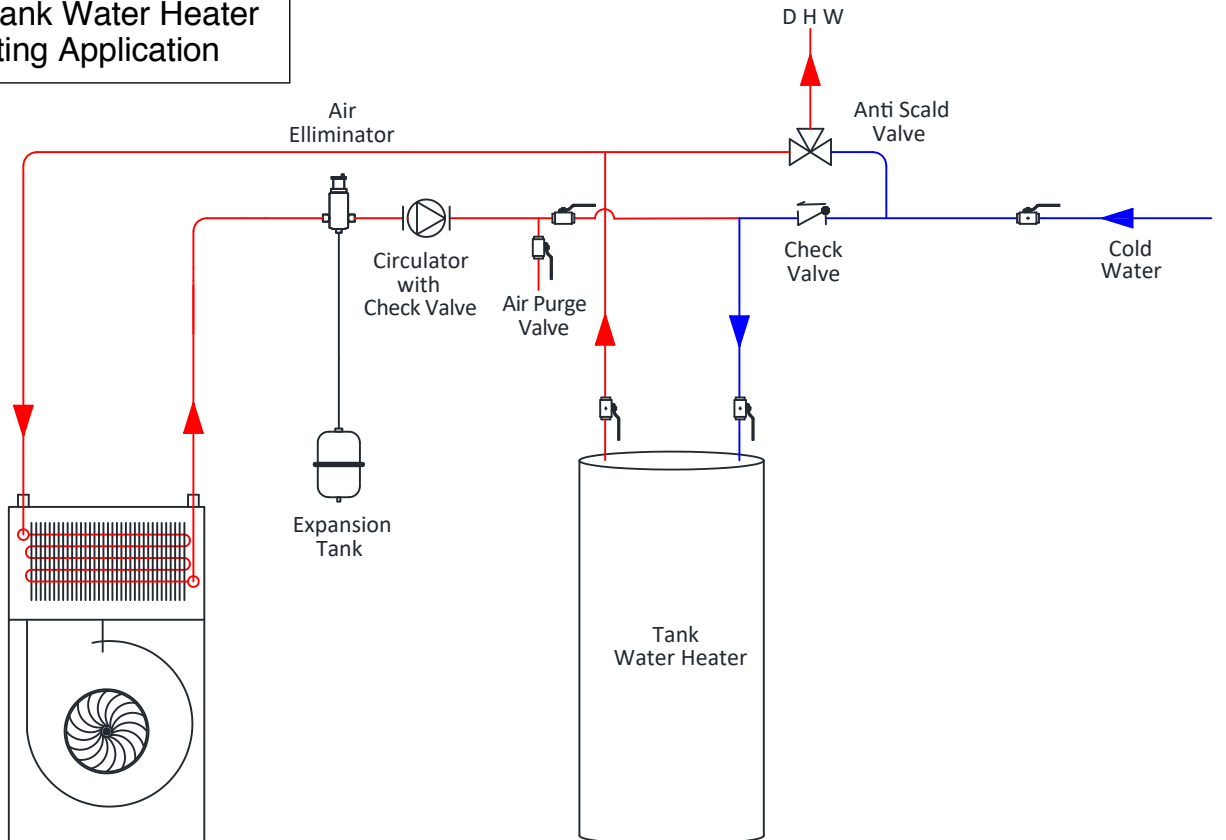

AHU with Tankless Boiler
Space Heating Application

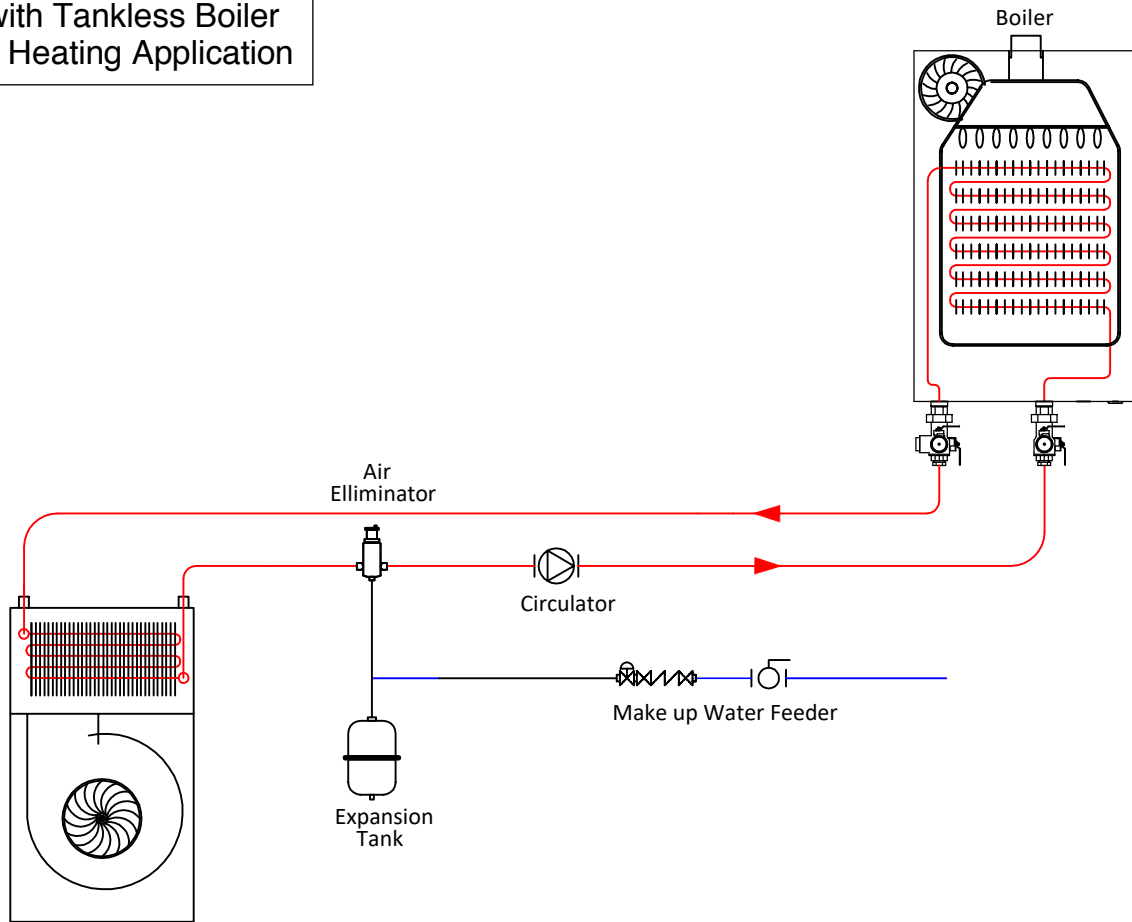

AHU with Combi Boiler
Space Heating Application

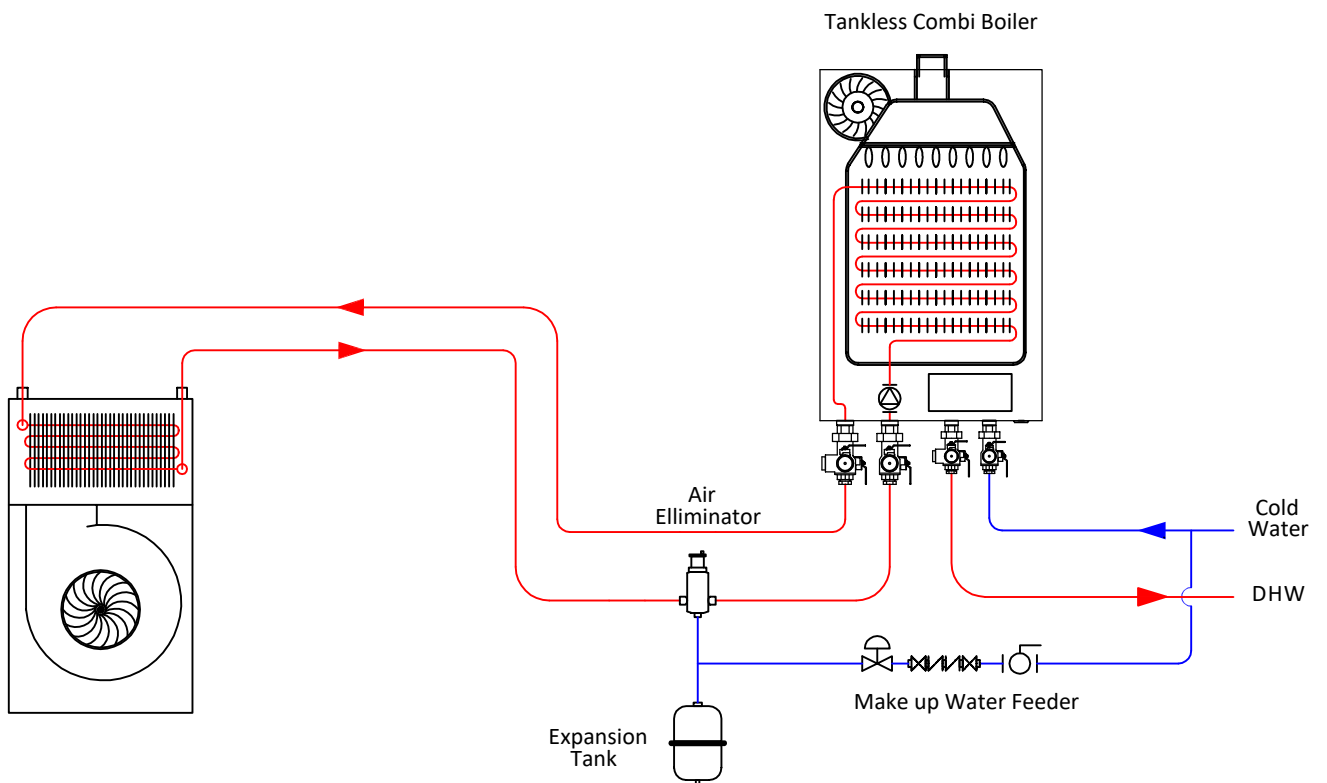

2 AHU with Boiler
Space Heating Application

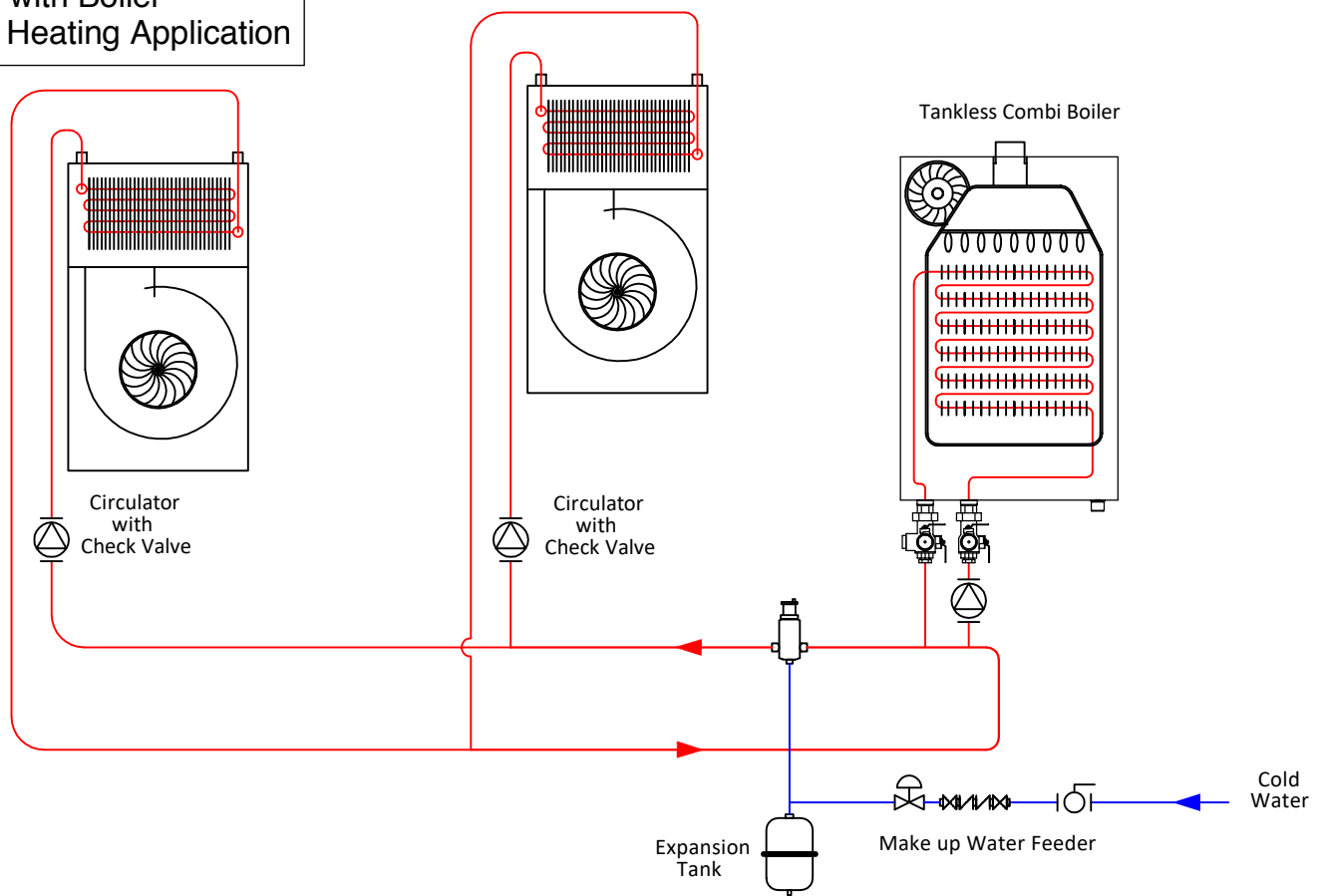

2 AHU with Combi Boiler
Space Heating Application

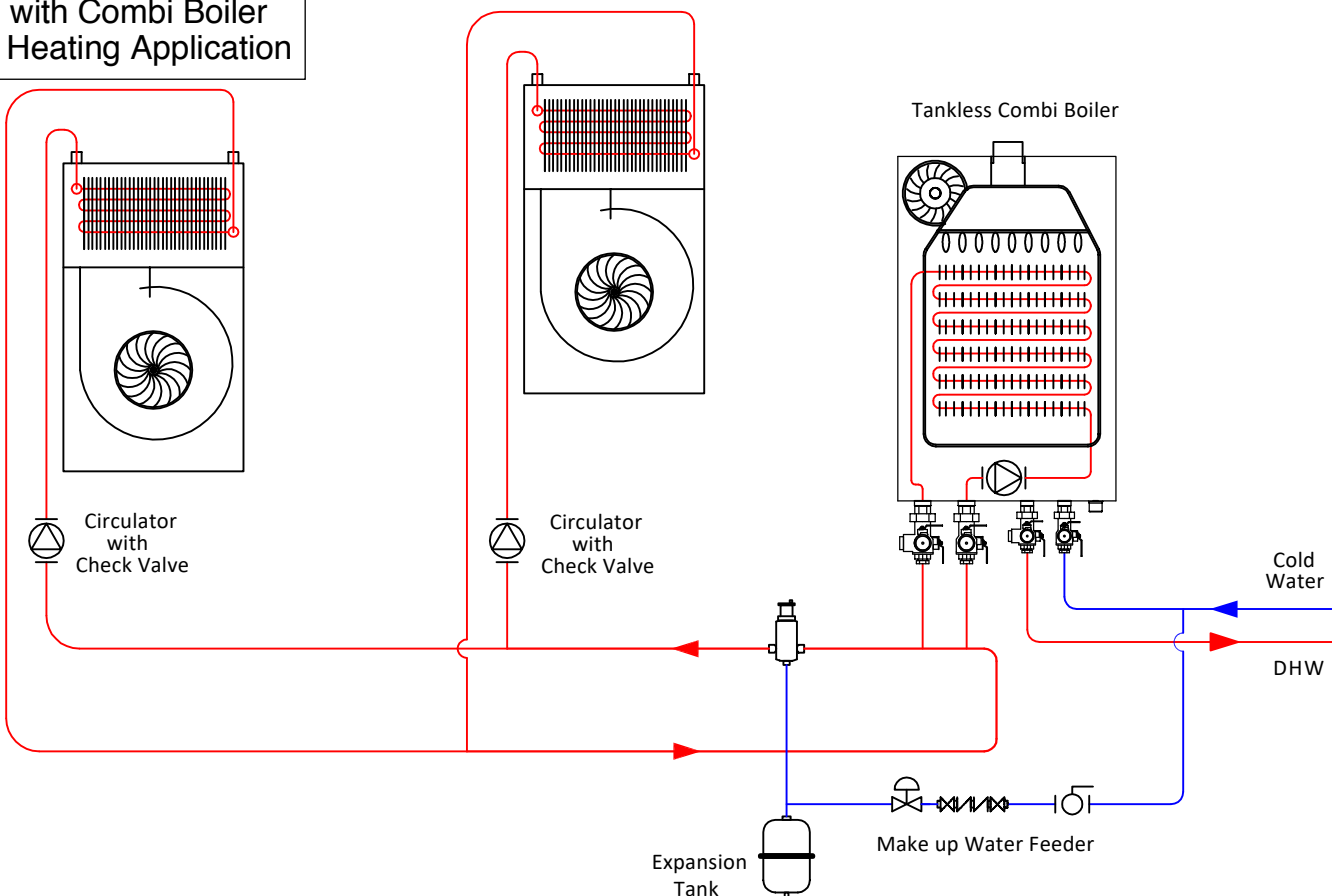

For the commonwealth of Massachusetts:

**COMMONWEALTH OF MASSACHUSETTS BOARD POLICY
COMBINATION SPACE HEATING / POTABLE WATER SYSTEM
(enacted 05-30-2012)**

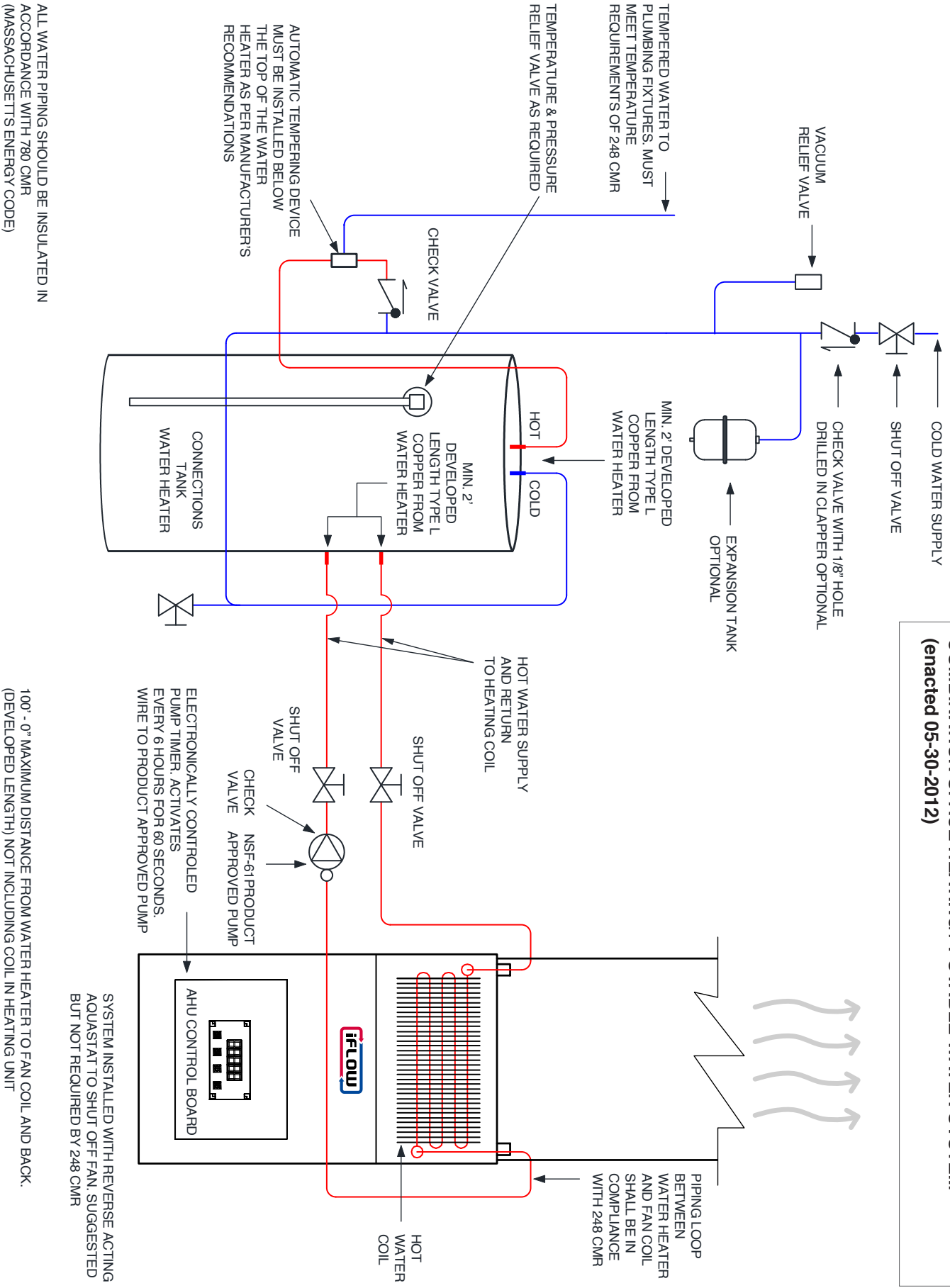

i Warranty and Contact Information

1) Warranty

CHANGE TERM OF WARRANTY TO YOURS

1. **Terms of Standard Warranty:** All iFLOW air handler parts are warranted and are to be free from defect in materials or faulty workmanship for a 36month period from the date of original installation subject to the Conditions of Warranty set out below. When the original date of installation cannot be determined, the warranty will be deemed to begin six months after the date of manufacture. Replacement parts will only carry the unexpired portion of the warranty.

2. **Warranty Procedure:** Warranty parts shall be replaced by a qualified local contractor or dealer and will require the following information: Model number, serial number, date of installation and an accurate description of the problem. Contractor or dealer will contact a local iFLOW distributor for replacement parts.

3. **Conditions of Warranty:** iFLOW assumes no costs for warranty service or costs associated with the replacement of parts. This warranty does not include labor, including diagnostic labor nor any freight associated with the repair service, or sales tax that might be incurred by the purchaser under this warranty. This warranty does not cover defects caused by improper installation, modifications, alterations, abuse or accident to, or misuse of the product or its operation in a manner contrary to the instructions included with this unit at the time of shipment, or failure to perform maintenance as detailed in aforementioned instructions. This warranty will not cover normal maintenance, equipment that has been moved from its original installation location, operated beyond rated capacity and at voltages other than the rate specified in the nameplate, acts of God such as floods, winds, fires and lightning, and exposed to corrosive elements such as salt, chlorine, fluorine or other damaging chemicals. This warranty will not cover part deficiencies due to lime or scale deposits. This warranty will not apply to damage or defect resulting from operation with system components other than those specified in the installation instructions, which are not authorized in writing by iFLOW manufacturing.

4. **Limitations of Warranty:** iFLOW manufacturing makes no express warranties other than the warranties set out above. All implied warranties including the implied warranties of merchantability and fitness for a particular purpose are excluded to the extent legally permissible, or are limited to a period of ONE year. Should such exclusion or limitation of warranty be unenforceable, such implied warranties are in any event limited to the duration of the express warranty, set forth above. Liability for incidental, punitive and/or consequential damages, whether arising out of breach warranty, breach of contract, negligence or otherwise, is excluded.

2) Contact Info

www.iflowhvac.com / 1-800-985-9227



INSTALLATION & OPERATION MANUAL iFLOW AIR HANDLER

Manual A2 Version: 2.2.0 / November 1, 2021



CONFORMS TO UL STANDARD
1995 CERTIFIED TO CSA
STANDARD C22.2 NO. 236



NSF 372



iFLOW HVAC INC.

29 Howden Road, Toronto, ON M1R 3C7
1-800-985-9227