



**iFLH - 140000**

**HIGH EFFICIENCY**

- Highest performance at 98% efficiency.(TPF 0.98 / CSA P .9-11)
- Ultra efficient heat exchanger design.
- Full modulation capabilities to suit space load requirements extending system run time and eliminating short cycles improving efficiency.
- Variable speed ECM blower provides control of air flow that can be adjusted to suit space load requirements and duct system.
- Intelligent pump modulation provides control of water flow that can be adjusted.

**COMFORT & FLEXIBILITY**

- Space zoning with integral control provides temperature control on each each level or specific rooms.
- Single, double, and quad smart zoning with integral control providing thermal storage technology.
- Hybrid heating system using dual fuels and match air handler with any hot water heat source.

**CONVENIENT & COST EFFECTIVE**

- Combine domestic hot water and space heating in one efficient system. Simple installation and easily configured parameters using push button display.
- Eliminates the venting of the space heating unit and reduces the cost of two appliances.
- Suitable for new construction, retrofits, renovations and upgrades.

**HIGH QUALITY**

- Heavy gauge steel cabinet with powder coated finish.
- Insulated and sealed cabinet reduces air leakage and noise.
- Canadian made, engineered, designed, and fully supported.

DESCRIPTION		IFLH - 140000
Heat Cap. Range	BTUH	27,834 - 62,786
Flow Rating	LPM / GPM	11.4 / 3
Return Air Temp.	°C / °F	22 / 72
E. S. P.	inWC	0.6 / 1.2
Airflow	SCFM	941 / 824
Cooling Capacity	Ton	1 - 2
Voltage	ACV/Hz/Ph	AC 120V 60Hz 1Ph
Motor	HP	0.5
	Type	ECM Eon / EC
Piping Connection	Supply	3 / 4" Male NPT
	Return	3 / 4" Male NPT
Hydronic Heating Coil	Aluminum Ultra Efficiency Fins, Copper Tubing	



**Compact Size**

**Fits in a closet**

**Multi Position**

**FREE iFLOW APP AVAILABLE**

- Easy management by smartphone
- Complete platform for IoT
- Smart thermostat for homeowner
- Easy set up for installer



## DIMENSION

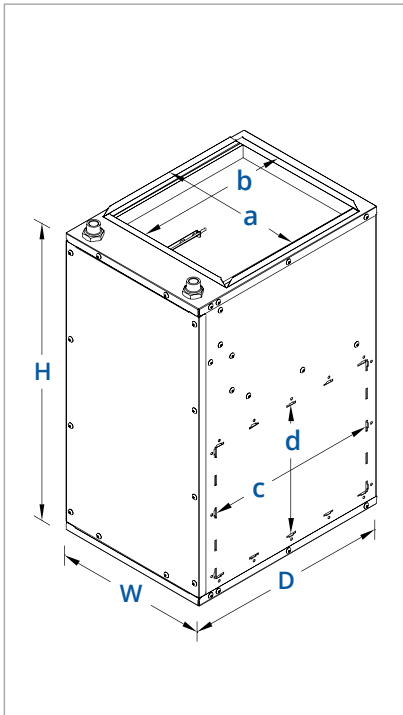

MODEL	IFLH-140000	
Width	14 "	(356 mm)
Depth	25 3/4 "	(654 mm)
Height	29 1/8 "	(740 mm)
a	13 "	(330.2 mm)
b	21 "	(533.4 mm)
c	23 "	(584.2 mm)
d	14 "	(355.6 mm)
Weight	36.2 lb	(80 kg)
Material	Cold Roll Steel Sheet Metal / Powder Coated	

## EZEE PLUMBING KIT (Quick Installation)

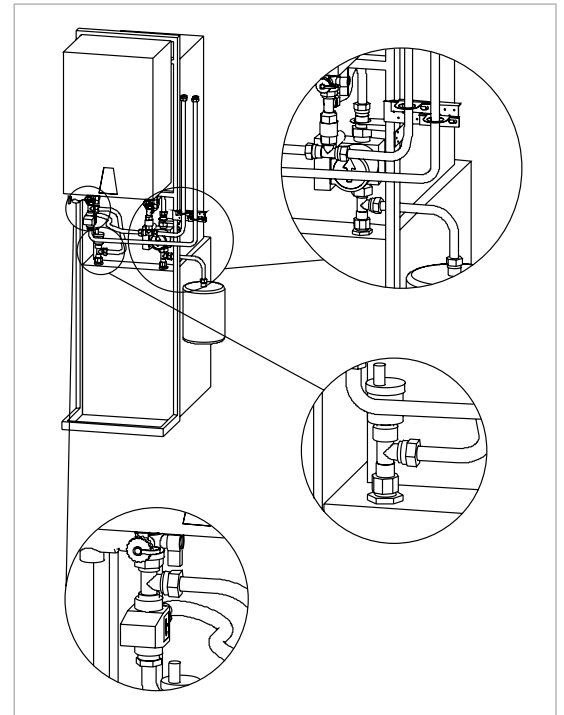

## WATER HEAT CAPACITY & WATER PRESSURE DROP CHART

H.EX. ROWS	ENTER-ING WATER TEMP.	3 GPM						4 GPM					
		CFM					W.P.D	CFM					W.P.D
		400	600	700	800	950		400	600	700	800	950	
4	120°F	17,365	21,756	23,654	25,347	27,834	2.9	18,425	23,097	25,653	27,246	29,906	4.3
	130°F	20,756	26,235	28,105	30,632	33,478	2.9	21,365	27,743	30,014	32,954	36,183	4.3
	140°F	24,142	30,754	33,521	36,065	37,729	2.8	24,845	32,469	35,478	38,549	42,376	4.2
	150°F	27,587	35,329	38,013	41,365	44,998	2.8	28,326	37,254	40,024	44,287	48,598	4.2
	160°F	30,965	39,865	43,247	46,759	50,869	2.8	31,824	41,987	45,726	49,976	54,843	4.1
	170°F	34,329	44,432	48,628	52,125	56,941	2.7	35,327	46,743	51,214	55,643	61,176	4.1
	180°F	37,734	49,032	54,573	57,683	62,786	2.7	39,836	51,458	56,429	61,398	67,497	4.0

STANDARD MODELS	Wi-Fi MODELS	ZONING MODELS (Wi-Fi)
iFLH-140000	iFLH-14000W	iFLH-16000D (Two Zones)
iFLH-160000	iFLH-16000W	iFLH-18000D (Two Zones)
iFLH-180000	iFLH-18000W	iFLH-18000Q (Four Zones)



**iFLOW HVAC INC.**  
 29 Howden Rd. Toronto ON  
 M1R 3C7  
 1-800-985-9227  
 www.iflowhvac.com